

CHARGE READY TRANSPORT



TAKE CHARGE:

A Guidebook to Fleet
Electrification and Infrastructure

CHARGE READY TRANSPORT



EXECUTIVE SUMMARY

4 INTRODUCTION

6 TRANSITIONING TO ELECTRICITY FOR YOUR FLEET

33 SCE'S CHARGE READY TRANSPORT PROGRAM FOR MEDIUM- AND HEAVY-DUTY VEHICLES

38 SCE'S CHARGE READY TRANSPORT ELECTRIFICATION PROCESS

44 ONGOING MAINTENANCE AND SUPPORT FOR YOUR EV CHARGING INFRASTRUCTURE

47 CONTINUING THE PROCESS

49 INTERESTED IN THE CHARGE READY TRANSPORT PROGRAM?

50 APPENDIX

55 GLOSSARY

EXECUTIVE SUMMARY

Medium- and heavy-duty vehicle fleets have a major impact on our air quality and environment. Electric medium- and heavy-duty fleets can reduce emissions and create a cleaner energy future here in California. That's the promise and potential of fleet electrification being realized today.

According to the California Air Resources Board (CARB), in 2018 the transportation sector accounted for the largest portion of total statewide greenhouse gas (GHG) emissions (39 percent), and the medium- and heavy-duty truck sector accounted for 23 percent of those emissions.¹ Spurred by the introduction of new technologies, infrastructure improvements and emission reduction legislation, fleet operators have begun to embrace electrification in earnest. In fact, organizations around the world are evaluating their needs to determine where electrification can fit into their operations.

A recent study found that 83 percent of large company fleet operators cite environmental benefits and 64 percent cite the lower total cost of ownership as top motivations for electrifying fleets.²

Electrification can help fleet operators reduce major top-line expenses such as maintenance and fueling costs, especially for medium- and heavy-duty fleets with fixed routes and charging locations. In the long term, fleet electrification can be a significant step toward meeting regulatory requirements as well as delivering the environmental benefits outlined above.

The backbone of any electric fleet is the charging infrastructure—the physical network that transfers electricity from the grid to the vehicles themselves. In this guidebook, you'll learn the basics of charging: how it works, selecting the right charging option and more.

You'll also get important information on how SCE can help with charger selection, site planning and design. In addition, you will learn about programs and rebates from SCE and others that can cover much of your infrastructure conversion costs.

Together, we can realize a cleaner, more sustainable future that benefits us all. Now is the time to drive electric.

¹ California Greenhouse Gas Emission Inventory—2018 edition, California Air Resources Board: <https://ww3.arb.ca.gov/cc/inventory/data/data.htm>

² Curve Ahead: The Future of Fleet Electrification, a 2018 UPS/GreenBiz Research Study: https://sustainability.ups.com/media/UPS_GreenBiz_Whitepaper_v2.pdf

CHARGE READY TRANSPORT

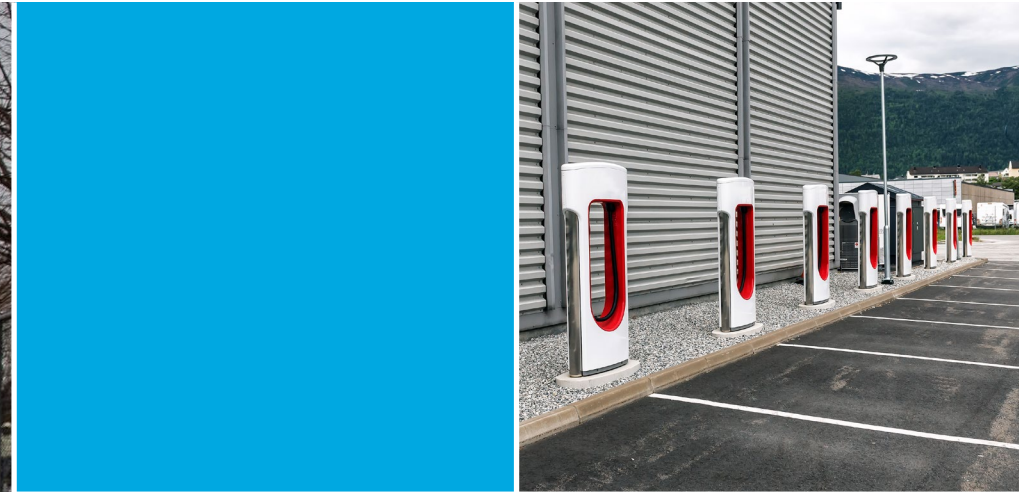

INTRODUCTION

There's never been a better time to make the move to electric for your medium- and heavy-duty fleets. Not only have manufacturers dramatically expanded their production of medium- and heavy-duty electric vehicles (EVs), but the necessary charging infrastructure has also grown to include several reliable, cost-effective options designed to reduce the overall cost of ownership and ongoing fleet operations. Additionally, companies transitioning to an electric fleet gain advantages of being sustainable leaders ready to meet California's clean energy goals.

In the following pages, you'll get helpful advice on how to best select, install and maintain the right charging solution to help you electrify your fleet. It's our goal to provide you with the information you need to:

- Estimate your fleet's baseline energy needs and charging time periods.
- Identify the charging equipment options that meet your electric fleet's needs in terms of charger type, charge speed and cost.
- Develop charging station configurations that work with your facility's existing space, support current and future operations, maximize equipment lifecycles and control costs.
- Speed up and simplify your project design, permitting and construction.
- Discuss the essential details of your electric service and electricity time-of-use periods.
- Find funding opportunities to reduce your total project costs.

Sample calculations, average costs and key term definitions are included with supporting graphics for your general reference. However, as you develop your own charging solution it's important to consult your vehicle manufacturer, SCE, local jurisdiction(s) and other relevant entities for project-specific guidance.

Visit www.sce.com/CRT to learn more and fill out an interest form to connect to an SCE EV Support Team member. If you're already connected, contact your Account Manager or EV Support Team member to discuss the findings herein and take the next step toward electrifying your fleet.

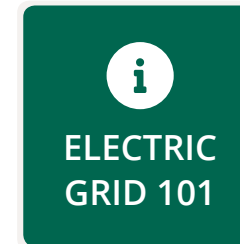

Want to learn more about the electric grid and how you get electricity? Check out this additional resource in the **Appendix**.

CHARGE READY TRANSPORT

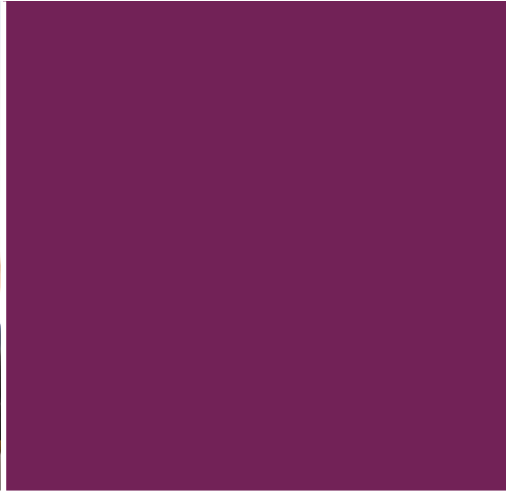

Transitioning to
electricity for
your fleet.



2 EXECUTIVE SUMMARY

4 INTRODUCTION

6 **TRANSITIONING TO ELECTRICITY FOR YOUR FLEET**

33 SCE'S CHARGE READY TRANSPORT PROGRAM FOR MEDIUM- AND HEAVY-DUTY VEHICLES

38 SCE'S CHARGE READY TRANSPORT ELECTRIFICATION PROCESS

44 ONGOING MAINTENANCE AND SUPPORT FOR YOUR EV CHARGING INFRASTRUCTURE

47 CONTINUING THE PROCESS

49 INTERESTED IN THE CHARGE READY TRANSPORT PROGRAM?

50 APPENDIX

55 GLOSSARY

TRANSITIONING TO ELECTRICITY FOR YOUR FLEET

There are several important infrastructure-related factors to address if you are considering transitioning your fleet from conventionally fueled vehicles (gasoline and diesel) to electric vehicles. Some of these factors involve familiar issues and decisions you already know from operating gas or diesel vehicles. Others introduce new concepts that are unique to EVs, such as the installation of a charger, also referred to as electric vehicle supply equipment (EVSE).

To plan for electric charging infrastructure, every project should start by clearly defining the scope and details of your planned EV deployment. This includes number and type of vehicles, planned duty cycle (daily range and hours of operation), and planned downtime when the vehicles could charge. This information allows you to build all other project components around properly charging the selected EVs to support implementing them in a way that best fits your fleet's operation and bottom-line. This section provides guidance for evaluating your fleet charging needs, charging equipment options and site feasibility.

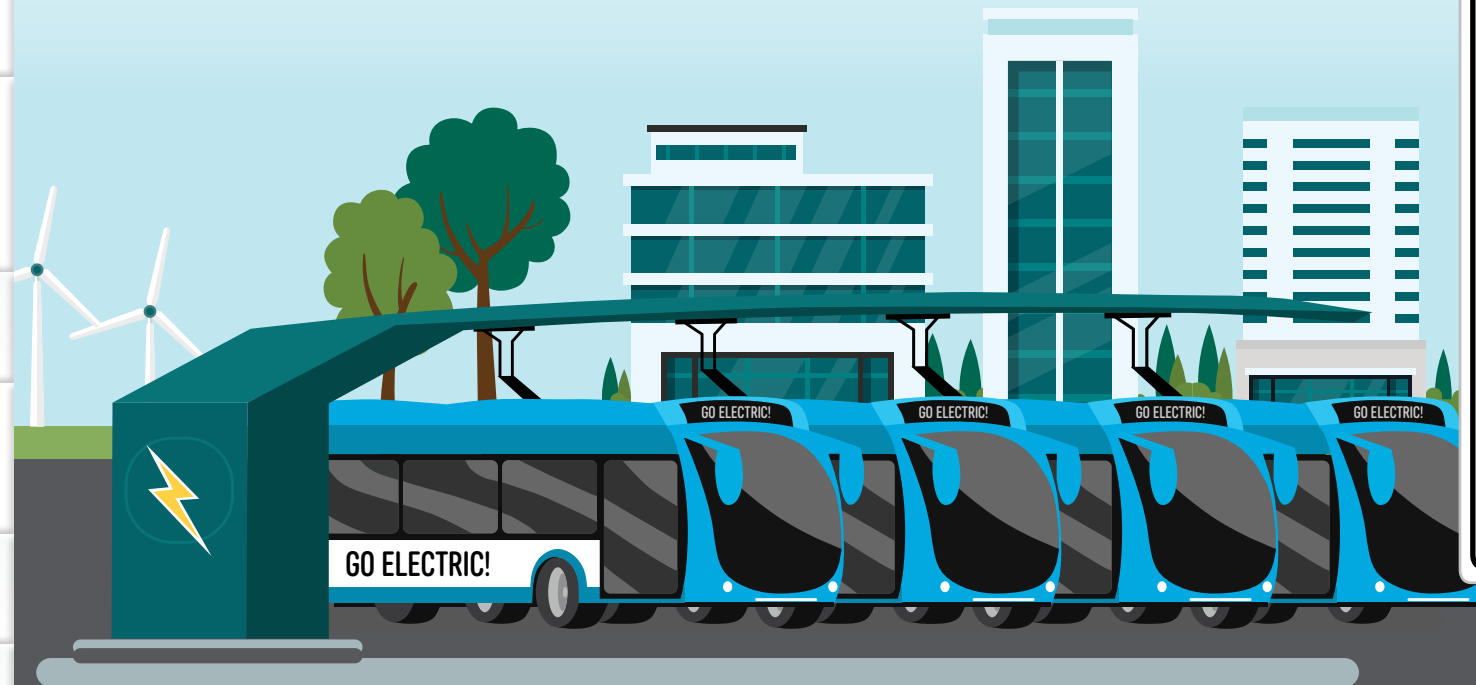

WHICH EV IS RIGHT FOR YOU?

The market for electric trucks, buses and off-road equipment is growing rapidly, with new vehicles being released every year. If you are interested in learning more about EVs available for your fleet type, your SCE Account Manager or EV Support Team member can help. Contact your Account Manager or fill out an interest form at www.sce.com/CRTform to get started.

CHARGE READY TRANSPORT

2 EXECUTIVE SUMMARY

4 INTRODUCTION

6 **TRANSITIONING TO ELECTRICITY FOR YOUR FLEET**

33 **SCE'S CHARGE READY TRANSPORT PROGRAM FOR MEDIUM- AND HEAVY-DUTY VEHICLES**

38 **SCE'S CHARGE READY TRANSPORT ELECTRIFICATION PROCESS**

44 **ONGOING MAINTENANCE AND SUPPORT FOR YOUR EV CHARGING INFRASTRUCTURE**

47 CONTINUING THE PROCESS

49 **INTERESTED IN THE CHARGE READY TRANSPORT PROGRAM?**

50 APPENDIX

55 GLOSSARY

CHOOSING THE RIGHT EV CHARGING INFRASTRUCTURE FOR YOUR FLEET

Your new EV fleet vehicles will need to do the work required to keep your operations running. The initial steps in developing your charging infrastructure are to determine how much energy each vehicle will need over the course of an average day (load profile) and the time it will take to deliver that energy. Knowing the answers to these questions will help you select the equipment you'll need to fuel your vehicles in a timely and cost-effective manner and forecast the cost of your electricity. Figure 1 below illustrates which pieces of information you will need and how they relate to your load profile; the examples on the following pages walk you through the actual calculations to complete the process.

FIGURE 1:
Components and process for developing your load profile.

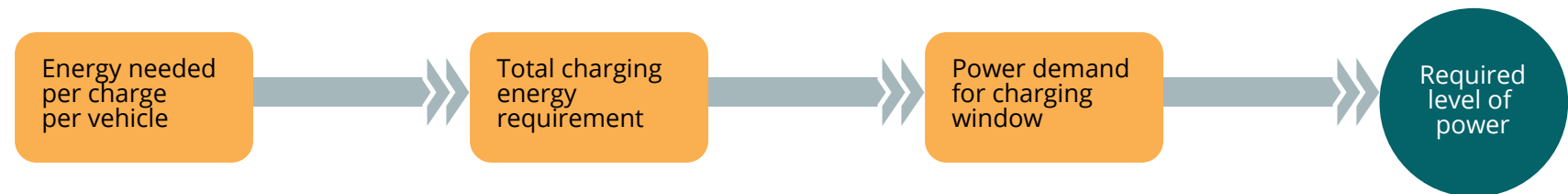

TERMS YOU NEED TO KNOW

Average power: The average amount of power that your fleet requires at any given time while charging

Charge rate: The rate at which a battery can charge, measured in kilowatts (kW)

Charging window: The period of time in your fleet's duty cycle when vehicles can charge, measured in hours

Duty cycle: The hours per day or proportion of time that a vehicle is operated per day

EV or BEV: Electric vehicle, sometimes referred to as battery electric vehicle

EVSE: Electric vehicle supply equipment to charge electric vehicles (i.e., the charger)

kW: Kilowatt, the unit of measure for power.

kWh: Kilowatt-hour, the unit of measure for electrical energy

Load profile: The amount(s) of power that your fleet requires on an hourly basis over the course of a day

CHARGE READY TRANSPORT

2 EXECUTIVE SUMMARY

4 INTRODUCTION

6 TRANSITIONING TO ELECTRICITY FOR YOUR FLEET

33 SCE'S CHARGE READY TRANSPORT PROGRAM FOR MEDIUM- AND HEAVY-DUTY VEHICLES

38 SCE'S CHARGE READY TRANSPORT ELECTRIFICATION PROCESS

44 ONGOING MAINTENANCE AND SUPPORT FOR YOUR EV CHARGING INFRASTRUCTURE

47 CONTINUING THE PROCESS

49 INTERESTED IN THE CHARGE READY TRANSPORT PROGRAM?

50 APPENDIX

55 GLOSSARY

CHOOSING THE RIGHT EV CHARGING INFRASTRUCTURE FOR YOUR FLEET (CONTINUED)

A good place to start is to work with your vehicle manufacturer to estimate your EV's energy consumption in your specific operations. Energy is calculated in terms of kWh per mile (or kWh per hour for some off-road equipment). Note: While traditional fuel economy is better when the miles-per-gallon figure is higher, with electricity, economy is better when the kWh per mile is lower. In other words, the lower your kWh per mile, the more you save because the vehicle is drawing less power for each mile traveled. View some typical energy consumption rates below:

A member of our EV Support Team can help at any stage of your electrification process. Go to www.sce.com/CRTform and fill out an interest form or, if you have an Account Manager already, contact them directly.

FIGURE 2: Typical EV energy consumption rates for medium and heavy duty vehicles.

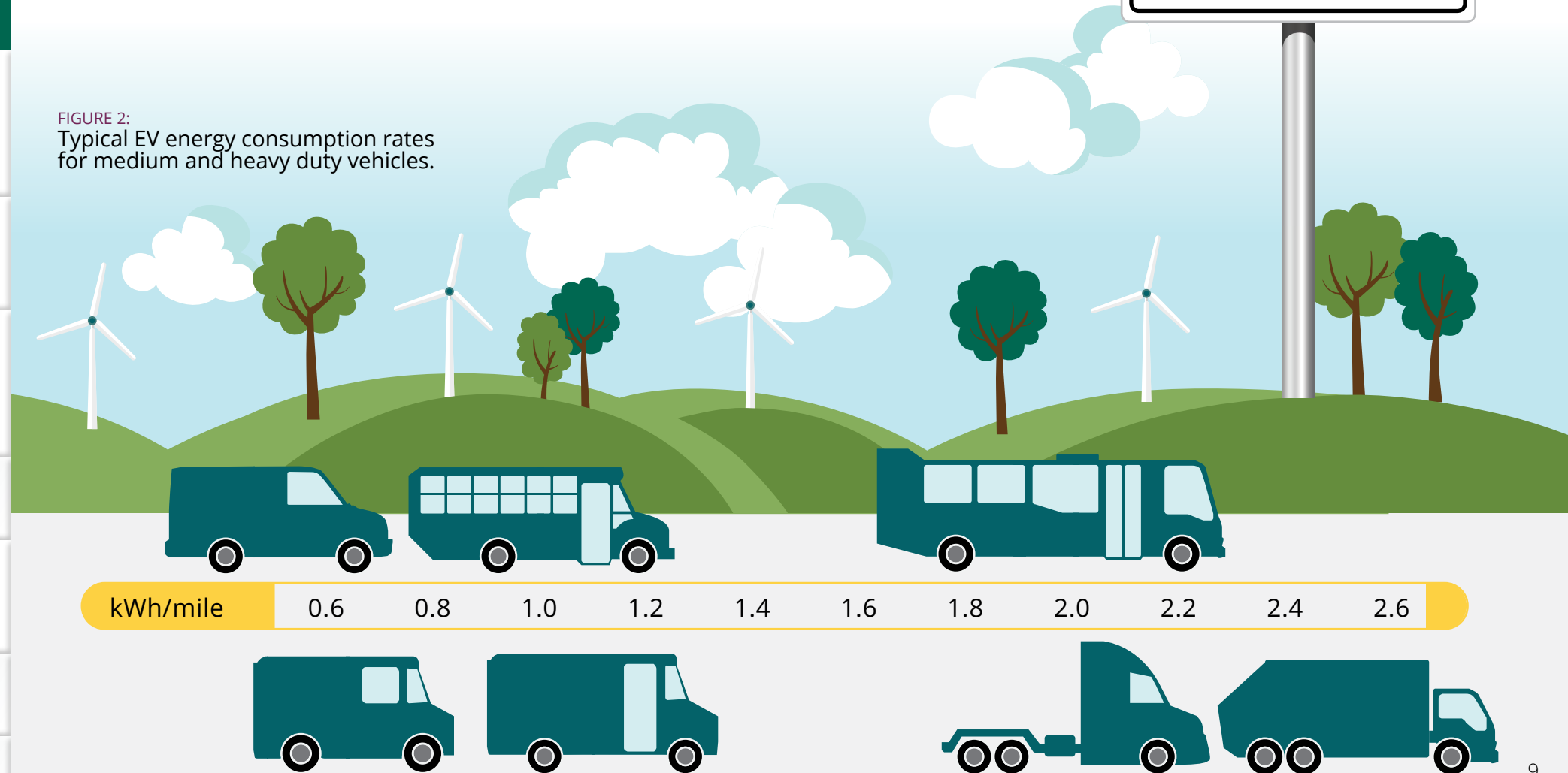

CHARGE READY TRANSPORT

2 EXECUTIVE SUMMARY

4 INTRODUCTION

6 **TRANSITIONING TO ELECTRICITY FOR YOUR FLEET**

33 SCE'S CHARGE READY TRANSPORT PROGRAM FOR MEDIUM- AND HEAVY-DUTY VEHICLES

38 SCE'S CHARGE READY TRANSPORT ELECTRIFICATION PROCESS

44 ONGOING MAINTENANCE AND SUPPORT FOR YOUR EV CHARGING INFRASTRUCTURE

47 CONTINUING THE PROCESS

49 INTERESTED IN THE CHARGE READY TRANSPORT PROGRAM?

50 APPENDIX

55 GLOSSARY

CHOOSING THE RIGHT EV CHARGING INFRASTRUCTURE FOR YOUR FLEET

(CONTINUED)

Once you have estimated your vehicle's electric fuel economy, you can use the following steps to determine your basic load profile.

- 1 To start, you'll want to calculate how much energy will be needed to charge each electric vehicle at the end of the day. This will be the vehicle's electric fuel economy (kWh per mile) multiplied by the miles driven since the last full charge.
- 2 To determine the total energy needed to charge the entire fleet, add the energy needed for each vehicle.
- 3 Next, determine how many hours the vehicles are in the yard and available for charging (the charging window). For example, if all the vehicles at the fleet yard are only available for charging between 6 p.m. and 4 a.m., then there is a 10-hour charging window open to deliver the required electricity to the vehicles. The average power required to charge a vehicle is equal to its charging energy (from step 1) divided by the number of hours in the charging window. The average power required for the entire fleet is equal to the fleet energy need (from step 2) divided by the number of hours in the charging window.

CALCULATE YOUR ENERGY NEEDS



ENERGY NEEDED PER CHARGE

$$\text{Charging energy requirement (kWh/charge)} = \text{VMT (vehicle miles traveled between charges)} \times \text{EV energy consumption rate (kWh/mile)}$$



TOTAL CHARGING ENERGY REQUIREMENT

$$\text{Total charging energy requirement (kWh/charge)} = \text{Charging energy requirement Vehicle 1} + \text{Charging energy requirement Vehicle 2} + \text{Charging energy requirement Vehicle 3}$$



AVERAGE POWER REQUIRED TO CHARGE

$$\text{Average power demand (kW)} = \frac{\text{Total charging energy requirement (kWh/charge)}}{\text{Charging window (hours)}}$$

CHARGE READY TRANSPORT

2 EXECUTIVE SUMMARY

4 INTRODUCTION

6 TRANSITIONING TO ELECTRICITY FOR YOUR FLEET

33 SCE'S CHARGE READY TRANSPORT PROGRAM FOR MEDIUM- AND HEAVY-DUTY VEHICLES

38 SCE'S CHARGE READY TRANSPORT ELECTRIFICATION PROCESS

44 ONGOING MAINTENANCE AND SUPPORT FOR YOUR EV CHARGING INFRASTRUCTURE

47 CONTINUING THE PROCESS

49 INTERESTED IN THE CHARGE READY TRANSPORT PROGRAM?

50 APPENDIX

55 GLOSSARY

CHOOSING THE RIGHT EV CHARGING INFRASTRUCTURE FOR YOUR FLEET (CONTINUED)

Vehicles that are only available for short time periods will require faster charging speeds to deliver the same amount of energy as those vehicles that can be charged over longer periods of time. Faster charging typically requires more-expensive chargers and infrastructure, so using the maximum practical time period for charging each vehicle can reduce costs. Figure 3 illustrates the difference in power demand when vehicles are charged over a four-hour window (requiring 175 kW peak power) versus a 10-hour window (requiring 75 kW peak power).

FIGURE 3:
Power demand over four- and 10-hour charging windows.

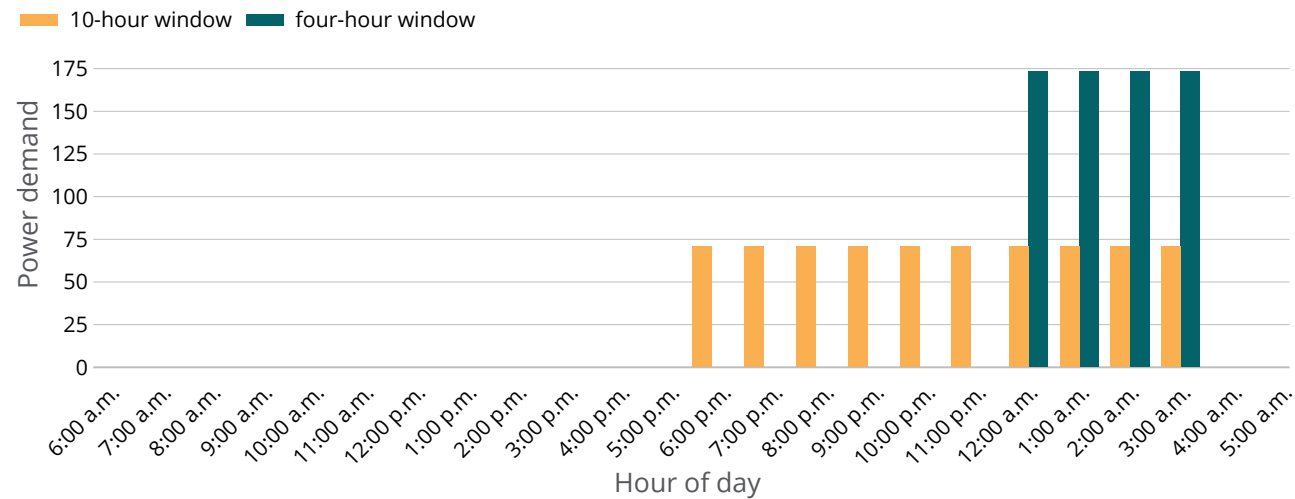

The above is an illustration of how a vehicle's dwell time dictates the power needed from an EVSE. This example is typical for a transit bus. If the bus has a 10-hour dwell time window available to charge, then it can charge at a power level of 75kW (orange bars). If the bus only has a four-hour charging window, then it needs 175 kW to charge fully during the dwell (teal bars). This difference can impact the cost of the site infrastructure – higher-power chargers are more expensive than lower-power chargers and, in some cases, require more expensive infrastructure.

CHARGE READY TRANSPORT

2 EXECUTIVE SUMMARY

4 INTRODUCTION

6 TRANSITIONING TO ELECTRICITY FOR YOUR FLEET

33 SCE'S CHARGE READY TRANSPORT PROGRAM FOR MEDIUM- AND HEAVY-DUTY VEHICLES

38 SCE'S CHARGE READY TRANSPORT ELECTRIFICATION PROCESS

44 ONGOING MAINTENANCE AND SUPPORT FOR YOUR EV CHARGING INFRASTRUCTURE

47 CONTINUING THE PROCESS

49 INTERESTED IN THE CHARGE READY TRANSPORT PROGRAM?

50 APPENDIX

55 GLOSSARY

CHOOSING THE RIGHT EV CHARGING INFRASTRUCTURE FOR YOUR FLEET (CONTINUED)

More complex load profiles exist when not all vehicles can be charged during the same time period or at the same rate. For example, Figure 4 illustrates the load profile from three vehicles that arrive at the yard at different times, but must all finish their charging at the same time. In Figure 4, all vehicles must depart at 3 a.m., but vehicle one arrives at 6 p.m., vehicle two arrives at 9 p.m. and vehicle three arrives at 11 p.m. This allows for a nine-hour, six-hour, and four-hour charging window, respectively. Fleets may have multiple charging windows per day, depending on when and how vehicles are used.

FIGURE 4:
Power demand for multiple vehicles with different charging windows due to arrival times.

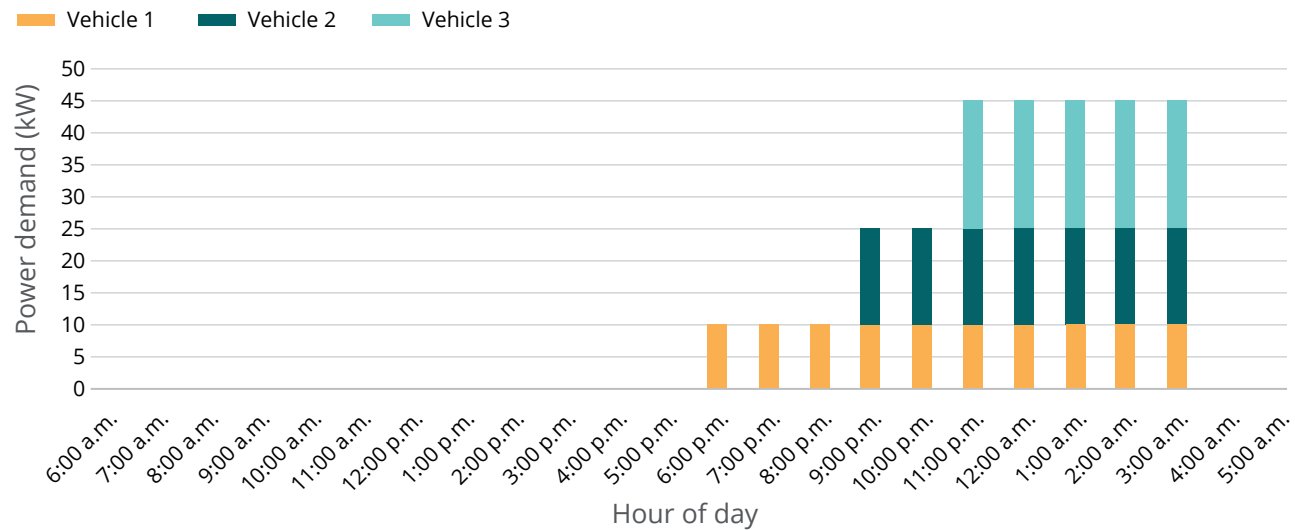

CHARGE READY TRANSPORT

2 EXECUTIVE SUMMARY

4 INTRODUCTION

6 **TRANSITIONING TO ELECTRICITY FOR YOUR FLEET**

33 **SCE'S CHARGE READY TRANSPORT PROGRAM FOR MEDIUM- AND HEAVY-DUTY VEHICLES**

38 **SCE'S CHARGE READY TRANSPORT ELECTRIFICATION PROCESS**

44 **ONGOING MAINTENANCE AND SUPPORT FOR YOUR EV CHARGING INFRASTRUCTURE**

47 **CONTINUING THE PROCESS**

49 **INTERESTED IN THE CHARGE READY TRANSPORT PROGRAM?**

50 **APPENDIX**

55 **GLOSSARY**

CHOOSING THE RIGHT EV CHARGING INFRASTRUCTURE FOR YOUR FLEET (CONTINUED)

Three examples for estimating your basic load profile.

Next, we look at three examples of EV charging scenarios that further illustrate the process of determining basic load profiles. In these examples, we will calculate the total energy demand, average power demand during a charging window and the average charging rate per vehicle. These values will be used later to inform infrastructure options and electricity prices.

These examples also show three different per-vehicle charging rates, ranging from 7 kW to 82.5 kW, which is important to consider when choosing the EVSE to meet your daily charging needs. If your charging scenario requires a higher kW charging rate than your EV can support, you must either select a different vehicle or extend your charging window to reduce the required charging rate. For example, if you need to charge at a rate of 50 kW per EV (to fulfill the time-per-charger requirements identified in your EV charging scenario) but the EV you have selected can only accept a charge rate of 25 kW, your charging scenario does not work for the EV type chosen.

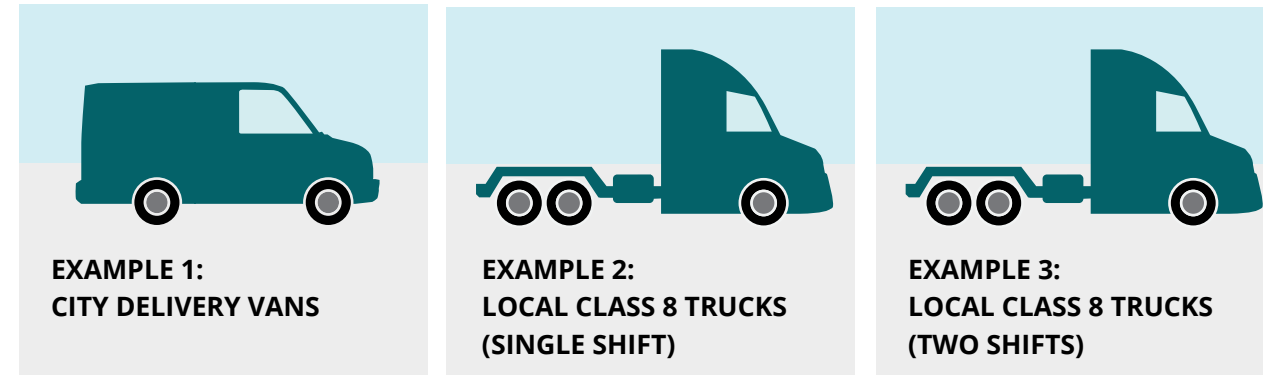

CHARGE READY TRANSPORT

2 EXECUTIVE SUMMARY

4 INTRODUCTION

6 TRANSITIONING TO ELECTRICITY FOR YOUR FLEET

33 SCE'S CHARGE READY TRANSPORT PROGRAM FOR MEDIUM- AND HEAVY-DUTY VEHICLES

38 SCE'S CHARGE READY TRANSPORT ELECTRIFICATION PROCESS

44 ONGOING MAINTENANCE AND SUPPORT FOR YOUR EV CHARGING INFRASTRUCTURE

47 CONTINUING THE PROCESS

49 INTERESTED IN THE CHARGE READY TRANSPORT PROGRAM?

50 APPENDIX

55 GLOSSARY

CHOOSING THE RIGHT EV CHARGING INFRASTRUCTURE FOR YOUR FLEET (CONTINUED)



EXAMPLE 1: CITY DELIVERY VANS

A fleet of 10 delivery vans uses 0.7 kWh of electricity per mile. All vans travel an average of 100 miles per day. They return to the fleet yard by 6 p.m. and must be ready to depart by 4 a.m.

FIGURE 5: Average power demand for 10 delivery vans over night.

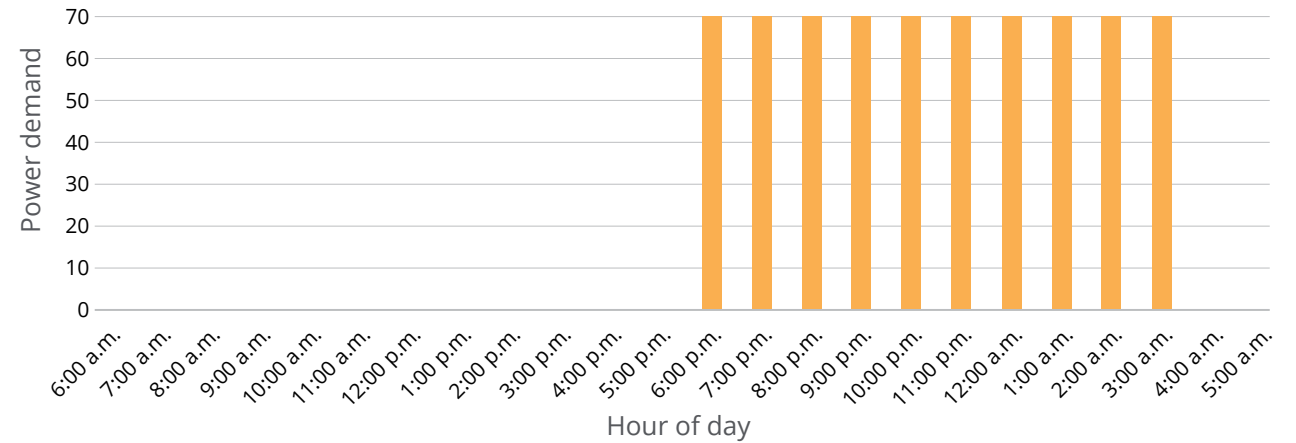

Charging window energy requirement

$$\begin{aligned}
 &\text{Energy (kWh)} \\
 &= \\
 &10 \text{ vehicles} \\
 &\times \\
 &100 \text{ miles/vehicle/day} \\
 &\times \\
 &0.7 \text{ kWh/mile} \\
 &= \\
 &700 \text{ kWh/day}
 \end{aligned}$$

Charging window

All vehicles return to the fleet yard by 6 p.m. and must be ready to depart by 4 a.m. Therefore, the charging window is **10 hours**.

Load profile and average power demand

All vehicles are available for the same charging window, so the load profile shows a flat power demand during the charging window (Figure 5).

$$\begin{aligned}
 &\text{Average power demand (kW)} \\
 &= \\
 &700 \text{ kWh} \\
 &\div \\
 &10 \text{ hours} \\
 &= \\
 &70 \text{ kW}
 \end{aligned}$$

Per-vehicle charging rate

Because your vehicles charge at the same time for the same amount of time, your per-vehicle charging rate is simply your average power demand distributed over the total number of trucks.

$$\begin{aligned}
 &\text{Per-vehicle charging rate (kW)} \\
 &= \\
 &70 \text{ kW} \\
 &\div \\
 &10 \text{ trucks} \\
 &= \\
 &7 \text{ kW/truck}
 \end{aligned}$$

CHARGE READY TRANSPORT

2 EXECUTIVE SUMMARY

4 INTRODUCTION

6 TRANSITIONING TO ELECTRICITY FOR YOUR FLEET

33 SCE'S CHARGE READY TRANSPORT PROGRAM FOR MEDIUM- AND HEAVY-DUTY VEHICLES

38 SCE'S CHARGE READY TRANSPORT ELECTRIFICATION PROCESS

44 ONGOING MAINTENANCE AND SUPPORT FOR YOUR EV CHARGING INFRASTRUCTURE

47 CONTINUING THE PROCESS

49 INTERESTED IN THE CHARGE READY TRANSPORT PROGRAM?

50 APPENDIX

55 GLOSSARY

CHOOSING THE RIGHT EV CHARGING INFRASTRUCTURE FOR YOUR FLEET (CONTINUED)



EXAMPLE 2: LOCAL CLASS 8 TRUCKS (SINGLE SHIFT)

Ten class 8 semitractors use 2.2 kWh of electricity per mile. All 10 trucks travel an average of 100 miles per day. They return to the fleet yard by 8 p.m. and must be ready to depart by 4 a.m.

FIGURE 6:
Average power demand for 10 heavy-duty trucks over one shift.

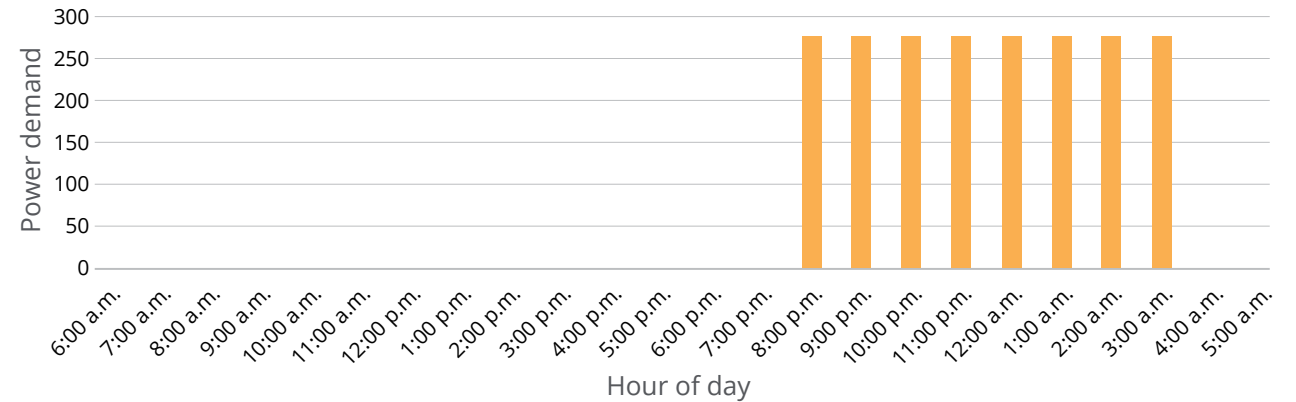

Charging window energy requirement	Charging window	Load profile and average power demand	Per-vehicle charging rate
$\begin{aligned} &\text{Energy (kWh)} \\ &= \\ &10 \text{ vehicles} \\ &\times \\ &100 \text{ miles/vehicle/day} \\ &\times \\ &2.2 \text{ kWh/mile} \\ &= \\ &2,200 \text{ kWh/day} \end{aligned}$	<p>All vehicles return to the fleet yard by 8 p.m. and must be ready to depart by 4 a.m. Therefore, the charging window is eight hours.</p>	<p>All vehicles are available for the same charging window, so the load profile is a flat power demand during the charging window (Figure 6).</p> $\begin{aligned} &\text{Average power demand (kW)} \\ &= \\ &2,200 \text{ kWh} \\ &\div \\ &8 \text{ hours} \\ &= \\ &275 \text{ kW} \end{aligned}$	$\begin{aligned} &\text{Per-vehicle charging rate (kW)} \\ &= \\ &275 \text{ kW} \\ &\div \\ &10 \text{ trucks} \\ &= \\ &27.5 \text{ kW/truck} \end{aligned}$

CHARGE READY TRANSPORT

2 EXECUTIVE SUMMARY

4 INTRODUCTION

6 TRANSITIONING TO ELECTRICITY FOR YOUR FLEET

33 SCE'S CHARGE READY TRANSPORT PROGRAM FOR MEDIUM- AND HEAVY-DUTY VEHICLES

38 SCE'S CHARGE READY TRANSPORT ELECTRIFICATION PROCESS

44 ONGOING MAINTENANCE AND SUPPORT FOR YOUR EV CHARGING INFRASTRUCTURE

47 CONTINUING THE PROCESS

49 INTERESTED IN THE CHARGE READY TRANSPORT PROGRAM?

50 APPENDIX

55 GLOSSARY

CHOOSING THE RIGHT EV CHARGING INFRASTRUCTURE FOR YOUR FLEET (CONTINUED)



EXAMPLE 3: LOCAL CLASS 8 TRUCKS (TWO SHIFTS)

Ten class 8 semitractors use 2.2 kWh of electricity per mile. All 10 trucks are used for two shifts per day and travel an average of 150 miles during the first shift and 100 miles during the second shift. The first shift returns to the fleet yard by 12 p.m. and must be ready to depart by 4 p.m. The second shift returns to the fleet yard by 12 a.m. and must be ready to depart by 4 a.m.

FIGURE 7:
Average power demand for 10 heavy-duty trucks over two shifts.

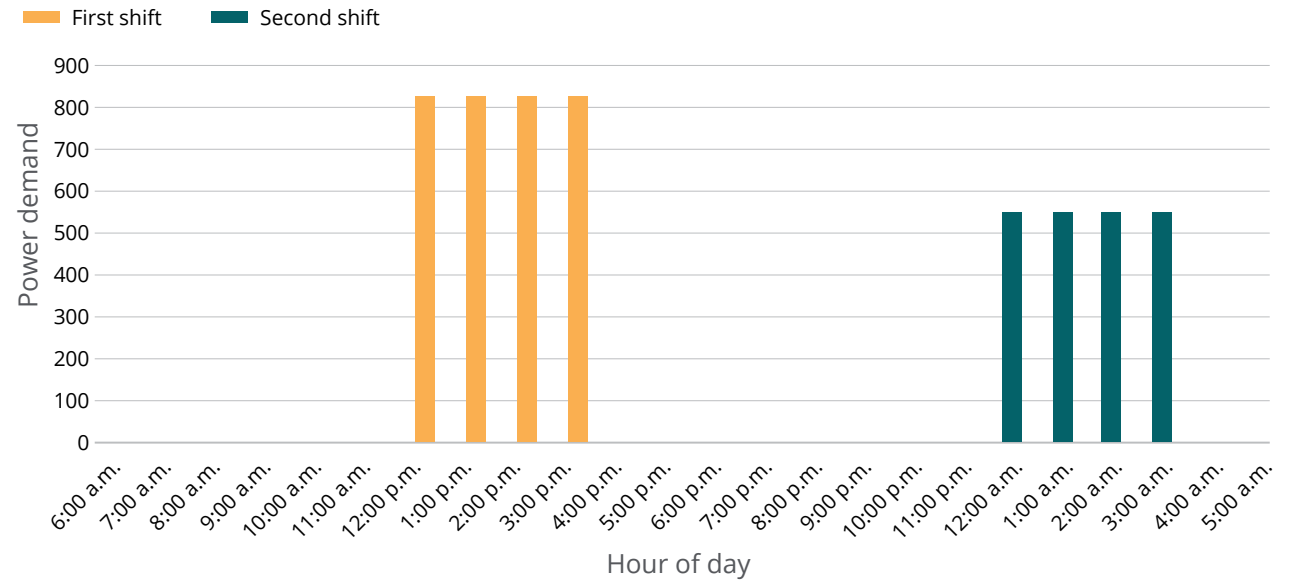

Charging window energy requirement

$$\begin{aligned} &\text{First shift energy (kWh)} \\ &= 10 \text{ vehicles} \\ &\quad \times 150 \text{ miles/vehicle/shift} \\ &\quad \times 2.2 \text{ kWh/mile} \\ &= 3,300 \text{ kWh/shift} \end{aligned}$$

$$\begin{aligned} &\text{Second shift energy (kWh)} \\ &= 10 \text{ vehicles} \\ &\quad \times 100 \text{ miles/vehicle/shift} \\ &\quad \times 2.2 \text{ kWh/mile} \\ &= 2,200 \text{ kWh/shift} \end{aligned}$$

Charging window

The first shift returns to the fleet yard by 12 p.m. and must be ready to depart by 4 p.m. The second shift returns to the fleet yard by 12 a.m. and must be ready to depart by 4 a.m. Therefore, the charging window is **four hours** for each shift.

Load profile and average power demand

All vehicles are available for the same charging window, so the load profile is a constant power demand during the charging window (Figure 7).

$$\begin{aligned} &\text{First shift average power demand (kW)} \\ &= 3,300 \text{ kWh} \div 4 \text{ hours} \\ &= 825 \text{ kW} \end{aligned}$$

$$\begin{aligned} &\text{Second shift average power demand (kW)} \\ &= 2,200 \text{ kWh} \div 4 \text{ hours} \\ &= 550 \text{ kW} \end{aligned}$$

Per-vehicle charging rate

$$\begin{aligned} &\text{First shift per-vehicle charging rate (kW)} \\ &= 825 \text{ kW} \div 10 \text{ trucks} \\ &= 82.5 \text{ kW/truck} \end{aligned}$$

$$\begin{aligned} &\text{Second shift per-vehicle charging rate (kW)} \\ &= 550 \text{ kW} \div 10 \text{ trucks} \\ &= 55 \text{ kW/truck} \end{aligned}$$

CHARGE READY TRANSPORT

2 EXECUTIVE SUMMARY

4 INTRODUCTION

6 **TRANSITIONING TO ELECTRICITY FOR YOUR FLEET**

33 **SCE'S CHARGE READY TRANSPORT PROGRAM FOR MEDIUM- AND HEAVY-DUTY VEHICLES**

38 **SCE'S CHARGE READY TRANSPORT ELECTRIFICATION PROCESS**

44 **ONGOING MAINTENANCE AND SUPPORT FOR YOUR EV CHARGING INFRASTRUCTURE**

47 **CONTINUING THE PROCESS**

49 **INTERESTED IN THE CHARGE READY TRANSPORT PROGRAM?**

50 APPENDIX

55 GLOSSARY

UNDERSTANDING ELECTRICITY RATES AND THE COST TO CHARGE YOUR FLEET

As an EV fleet operator, electricity becomes your “fuel,” and your electric bill becomes your fuel bill. However, unlike gasoline or diesel costs, electricity costs have multiple components and can vary depending on how a fleet charges. By understanding how electricity rates work, you can charge more efficiently and lower your electric bills.

The good news is that SCE's new EV rates have been restructured to remove much of the complexity and make it simpler for EV fleets to plan for efficient vehicle charging. In 2019, SCE released new rates EV-7, EV-8 and EV-9, explicitly designed for EV fleets. In order to qualify for these rates, you must have a dedicated electric meter specifically for the EVSE.

These new rates are structured with “time-of-use” periods in which electricity is more expensive during peak times (4 p.m. - 9 p.m.) and cheaper during off-peak times. Electricity costs also vary by month; rates during winter (October through May) are lower than during summer (June through September).

This rate structure helps fleet managers plan for when to charge their vehicles – when possible, charge as much as possible during off-peak times and as little as possible during on-peak times. In real-world operation, some fleets may need to charge on-peak at times, but fleet managers may find the flexibility to shift as much charging as possible to off-peak times.

If you have been researching how to deploy EV fleets or spoken with other fleet companies, you have probably come across the term Demand Charges. For many utilities and electricity rates, demand charges are a component of your bill that charges you according to your peak demand, or the maximum amount of power you use during the month. Depending on the rate structure and how you charge your fleet, demand charges can make up a large portion of your bill. In addition, if your usage spikes at any point during the month, for example if you charge all vehicles at once at full power instead of staggering the charging over a longer time, your bill for that month will have a higher demand charge. Because of this, it's important to be aware of and plan for demand charges.

SCE recognizes that fleets are concerned about potential demand charges. Therefore, as part of our new EV rate tariffs, the rates have zero demand charges through 2024. Suspending demand charges simplifies the billing for many fleets and, for some fleets, saves a lot of money. After 2024, demand charges filter back in over the following five years. This demand charge “holiday” gives

fleets the opportunity to deploy their initial fleets and experiment with different charging strategies to keep demand charges to a minimum. New technologies are also coming to market in the next few years to help fleets manage their vehicle charging demand.

It can be challenging for fleet managers who are unfamiliar with this information to understand their rate options. The next section explains SCE's commercial electric rate plans so you can manage your charging costs while fully meeting your fleet's charging needs.

CHARGE READY TRANSPORT

2 EXECUTIVE SUMMARY

4 INTRODUCTION

6 TRANSITIONING TO ELECTRICITY FOR YOUR FLEET

33 SCE'S CHARGE READY TRANSPORT PROGRAM FOR MEDIUM- AND HEAVY-DUTY VEHICLES

38 SCE'S CHARGE READY TRANSPORT ELECTRIFICATION PROCESS

44 ONGOING MAINTENANCE AND SUPPORT FOR YOUR EV CHARGING INFRASTRUCTURE

47 CONTINUING THE PROCESS

49 INTERESTED IN THE CHARGE READY TRANSPORT PROGRAM?

50 APPENDIX

55 GLOSSARY

OPPORTUNITIES TO MANAGE EV CHARGING COSTS

SCE's rates for EV fleets are based on time-of-use: rates are highest during on-peak periods (4 p.m. – 9 p.m.) and lower overnight, morning and mid-day. Rates are also higher in the summer months (June – September) and lower in the winter months (October – May).

NEW STANDARD TIME-OF-USE (TOU) PERIODS March 2019

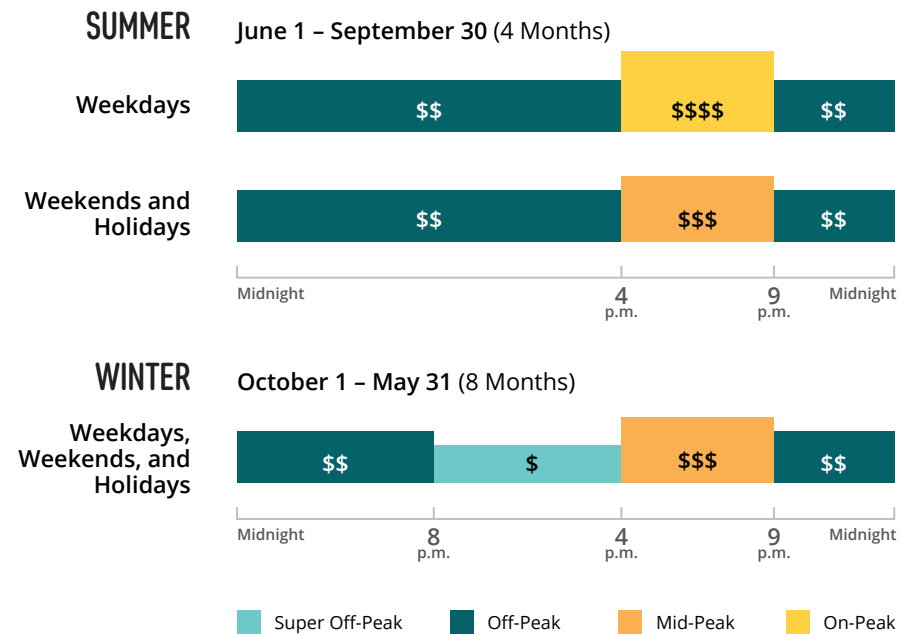

Holidays are New Year's Day, President's Day, Memorial Day, Independence Day, Labor Day, Veterans Day, Thanksgiving Day, and Christmas. When any holiday falls on a Sunday, the following Monday will be recognized as a holiday. However, no change will be made for holidays falling on a Saturday.



TERMS YOU NEED TO KNOW

EV demand: The amount of power (kW) supplied to EVs during charging

Rate structure: A set of parameters used to define the prices that a customer may be charged for power over time

Meter: A device that records the amount of power flowing through a circuit

Peak shaving: A strategy to reduce power consumption during periods of high demand

CHARGE READY TRANSPORT

2 EXECUTIVE SUMMARY

4 INTRODUCTION

6 **TRANSITIONING TO ELECTRICITY FOR YOUR FLEET**

33 SCE'S CHARGE READY TRANSPORT PROGRAM FOR MEDIUM- AND HEAVY-DUTY VEHICLES

38 SCE'S CHARGE READY TRANSPORT ELECTRIFICATION PROCESS

44 ONGOING MAINTENANCE AND SUPPORT FOR YOUR EV CHARGING INFRASTRUCTURE

47 CONTINUING THE PROCESS

49 INTERESTED IN THE CHARGE READY TRANSPORT PROGRAM?

50 APPENDIX

55 GLOSSARY

HOW MUCH COULD YOU SAVE BY SWITCHING TO ELECTRIC?

Ever wondered how much you could save by switching to an electric fleet? Use **SCE's Fleet Fuel Calculator** to estimate electrical fueling costs for medium- and heavy-duty electric vehicles. See the difference between electricity and your current fuel costs, fuel savings per mile, and much more. One of our EV Support Team members can walk you through the results for further costs savings.

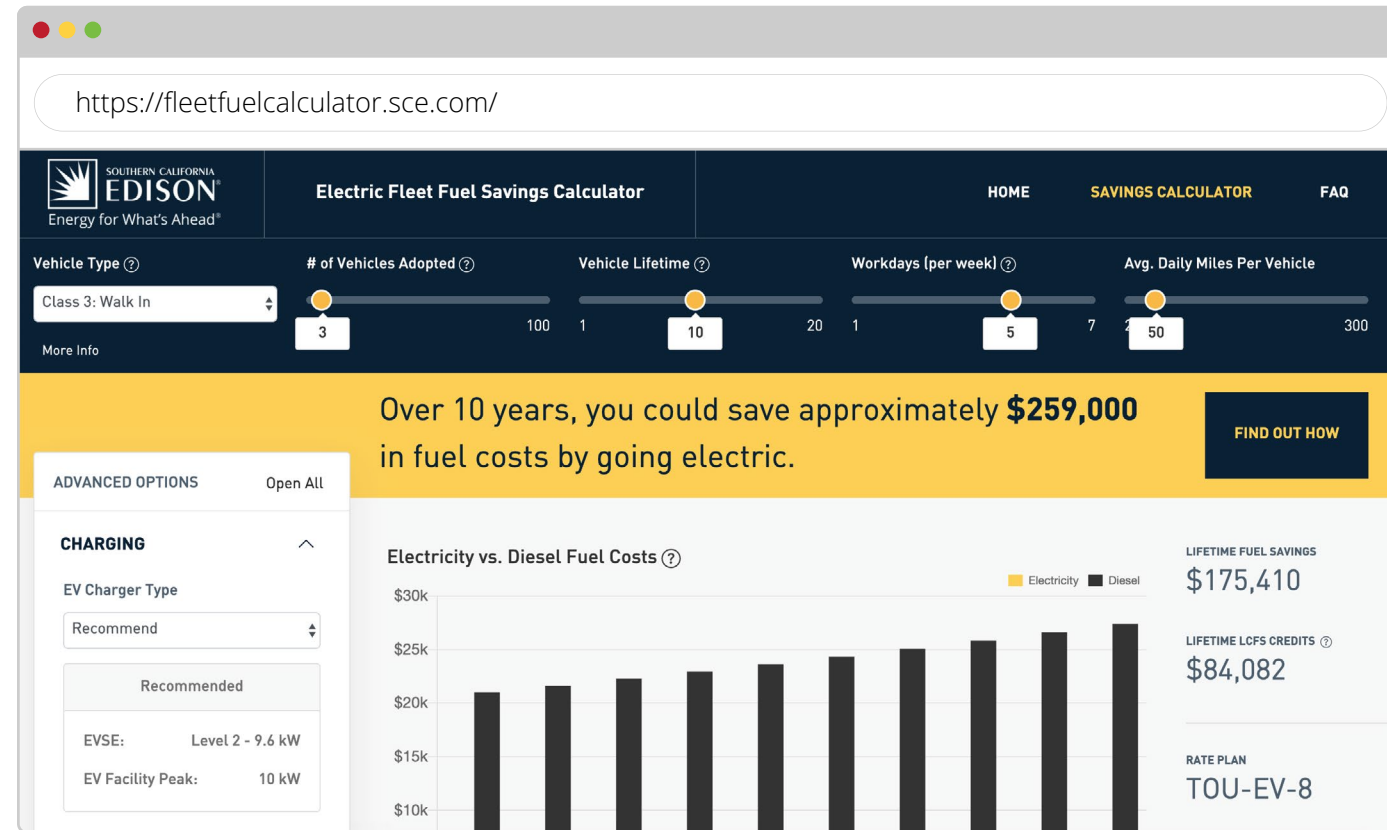

The above is a screenshot of the SCE Fleet Fuel Calculator tool in use. Your results will vary depending on the input provided.

CHARGE READY TRANSPORT

2 EXECUTIVE SUMMARY

4 INTRODUCTION

6 **TRANSITIONING TO ELECTRICITY FOR YOUR FLEET**

33 SCE'S CHARGE READY TRANSPORT PROGRAM FOR MEDIUM- AND HEAVY-DUTY VEHICLES

38 SCE'S CHARGE READY TRANSPORT ELECTRIFICATION PROCESS

44 ONGOING MAINTENANCE AND SUPPORT FOR YOUR EV CHARGING INFRASTRUCTURE

47 CONTINUING THE PROCESS

49 INTERESTED IN THE CHARGE READY TRANSPORT PROGRAM?

50 APPENDIX

55 GLOSSARY

ENERGY MANAGEMENT BEST PRACTICES

The previous sections described ways that using specific charging periods can optimize a fleet's transition to EVs in a cost-effective, operationally feasible manner. Additional energy management best practices include energy storage and an emergency preparedness plan.

Energy storage

Energy storage refers to any technology that can store electrical energy over a period of time. A steady power reserve can be valuable to fleets to reduce demand charge spikes, avoid energy charges during peak periods or mitigate issues from an unreliable power supply. In these scenarios, the energy storage resource typically draws power from a separate source or at a time when electricity prices are low. A fleet can then use that prepaid power when prices are high, or electricity is not available.

Batteries are the most common form of energy storage technology, and they are available in a range of capacities, physical sizes and chemistries. Depending on your basic load profile, EVSE options and level of power supply, energy storage may be a useful option to explore.

Emergency preparedness

While the electric grid is reliable, disruptions can occur. An emergency preparedness plan can minimize the impact of an outage. Answer the questions below to ensure your fleet is sufficiently prepared.

- **How much energy do you need?**
An emergency such as a natural disaster may halt your operations for several days, so you might not need 100 percent of your typical capacity.
- **How will you get enough energy?**
Energy storage and on-site generation are two options to keep your fleet charged.



TERMS YOU NEED TO KNOW

Generation: The process of producing electricity from a fuel or other energy source

CHARGE READY TRANSPORT

2 EXECUTIVE SUMMARY

4 INTRODUCTION

6 TRANSITIONING TO ELECTRICITY FOR YOUR FLEET

33 SCE'S CHARGE READY TRANSPORT PROGRAM FOR MEDIUM- AND HEAVY-DUTY VEHICLES

38 SCE'S CHARGE READY TRANSPORT ELECTRIFICATION PROCESS

44 ONGOING MAINTENANCE AND SUPPORT FOR YOUR EV CHARGING INFRASTRUCTURE

47 CONTINUING THE PROCESS

49 INTERESTED IN THE CHARGE READY TRANSPORT PROGRAM?

50 APPENDIX

55 GLOSSARY

UNDERSTANDING YOUR EVSE OPTIONS

Selecting which type of EVSE solution is right for you is based on your fleet type, fleet requirements and business or operational needs. Having the proper EVSE will maximize fleet efficiency and minimize energy costs.

An EVSE solution is comprised of three basic components:

1. **EVSE interface (physical charging)**
2. **Charger power type (AC vs. DC)**
3. **Charger level**

This section will provide a top-line overview of each of these components, along with a summary of the facts you need to select the right EVSE for your fleet application.

EVSE interfaces

There are two basic types of EVSE interfaces: 1) plug-in and 2) overhead. Each type is briefly described in Figure 8 with supporting details on the next couple of pages. Figures 9, 10 and 11 summarize the key features as well as the pros and cons of each type. Toward the end of this section, you'll also find some **general takeaways** to consider when selecting the right EVSE for your fleet.

FIGURE 8:
Basic EV charging interface types.

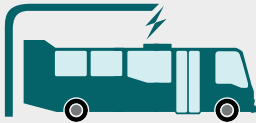
Type	Plug-in	Overhead
Activation	Manual	Automated
Connection	 Conductive	 Conductive
Power range	Up to 350 kW	Typically 350-500 kW
Voltage type	AC, DC and AC + DC	DC

CHARGE READY TRANSPORT

2 EXECUTIVE SUMMARY

4 INTRODUCTION

6 TRANSITIONING TO ELECTRICITY FOR YOUR FLEET

33 SCE'S CHARGE READY TRANSPORT PROGRAM FOR MEDIUM- AND HEAVY-DUTY VEHICLES

38 SCE'S CHARGE READY TRANSPORT ELECTRIFICATION PROCESS

44 ONGOING MAINTENANCE AND SUPPORT FOR YOUR EV CHARGING INFRASTRUCTURE

47 CONTINUING THE PROCESS

49 INTERESTED IN THE CHARGE READY TRANSPORT PROGRAM?

50 APPENDIX

55 GLOSSARY

UNDERSTANDING YOUR EVSE OPTIONS (CONTINUED)

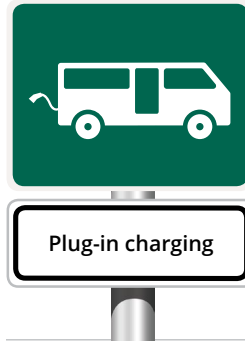

Plug-In charging is done via a charging cord that is manually plugged into an EV's charging receptacle. Plug-in charging is by far the most common interface used today. These are considered "conductive" systems because power is transferred to the vehicle via conductors in the plug and receptacle. (See Figure 9). There are many different plug-in interfaces based on various standards (e.g., SAE J1772, SAE Combo CCS1, CHAdeMO.) In addition, some EV manufacturers (e.g., Tesla) have adopted proprietary standards. Participants using on-road vehicles in SCE's Charge Ready Transport program must use standardized connectors and cannot choose a proprietary solution.



Overhead systems are another type of conductive interface that provide power by connecting an EV to a DC fast charger (DCFC) using a pantograph, as detailed in Figure 10. Because the pantograph can handle large conductors that would be difficult for an individual to manage in a manual plug-type interface, overhead systems can charge at higher power levels than plug-type interfaces. Currently, overhead charging is mostly used in specific transit bus applications. However, it could eventually be used to provide rapid charging for trucks and other heavy-duty applications (e.g., cargo-handling equipment).

At present, plug-in charging is the most common and widely available option based on existing vehicles and infrastructures. Overhead charging, while more powerful than a plug-in, is still limited to certain applications.

FIGURE 9: The EVSE plug connects with the EV receptacle to transmit power over a conductive system.

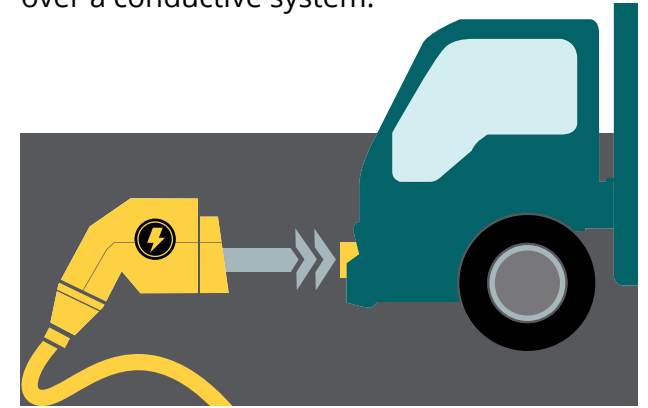
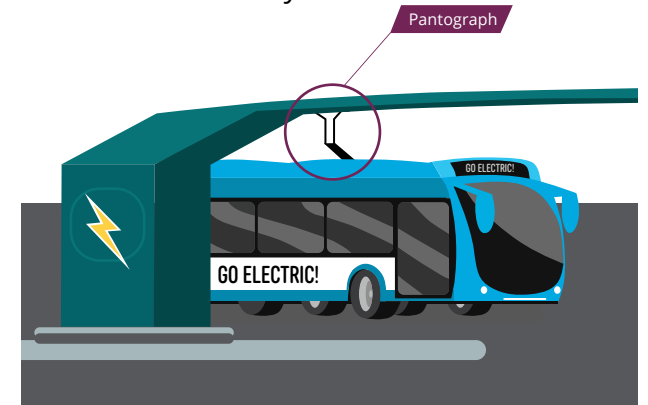

FIGURE 10: The DC fast charger uses a pantograph to transmit power over a conductive system.



Wireless charging stations are not currently approved for on-road use in SCE's Charge Ready Transport program at the time of publication, but be sure to check with an EV Support Team member during planning.

UNDERSTANDING YOUR EVSE OPTIONS (CONTINUED)

FIGURE 11: Advantages and disadvantages of EV charging interface types.

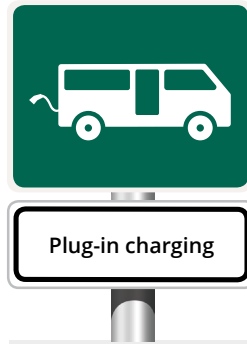

Manual conductive

PROS

- Proven solution (standard EV charging approach)
- Lower capital cost per charge port
- Very high power (>300 kW)
- Subsurface work generally limited to trenching for power cabinets

CONS

- Requires personnel to plug in and unplug vehicle for charging
- Cable management



Automated conductive

PROS

- No delay waiting for personnel to connect EV
- Similar subsurface work as manual systems

CONS

- Cable management/connection logistics
- Higher capital cost per port
- Large footprint
- Parking misalignment can prevent charging

CHARGE READY TRANSPORT

2 EXECUTIVE SUMMARY

4 INTRODUCTION

6 TRANSITIONING TO ELECTRICITY FOR YOUR FLEET

33 SCE'S CHARGE READY TRANSPORT PROGRAM FOR MEDIUM- AND HEAVY-DUTY VEHICLES

38 SCE'S CHARGE READY TRANSPORT ELECTRIFICATION PROCESS

44 ONGOING MAINTENANCE AND SUPPORT FOR YOUR EV CHARGING INFRASTRUCTURE

47 CONTINUING THE PROCESS

49 INTERESTED IN THE CHARGE READY TRANSPORT PROGRAM?

50 APPENDIX

55 GLOSSARY

UNDERSTANDING YOUR EVSE OPTIONS (CONTINUED)

Charger power type

In addition to the physical interface types described above, EVSE is further divided into AC and DC charging. AC charging essentially passes the voltage as is from the utility to the vehicle. On board the vehicle, electronics convert the AC power to the DC power that is required to charge the battery. AC charging is typically limited to power levels of 20 kW or less because vehicles may not have space for the larger electronics required to support higher power levels. There are some exceptions, particularly on off-road equipment where space is less constrained. Above 20 kW, the electronics required to convert power from AC to DC are placed outside the vehicle and the DC fast charger provides DC power to the EV. These chargers are currently capable of supplying power up to approximately 350 kW.

Charger level

Currently, most medium- and heavy-duty EVs in the U.S. are equipped for at least one of two standard plug-in charging levels. For lower power charging, an AC charger is typically specified (either Level 1 at 120 volts or Level 2 at 240 volts). Between 20 and 50 kW, vehicles may be equipped with both an AC and DC fast charger. Above 50 kW, most vehicles will be equipped with a DC fast charger. These chargers are summarized in **Figure 12**.

When determining which charging level works best for you, also consider the plug location of your current and/or future EVs.



TERMS YOU NEED TO KNOW

Voltage: Electrical pressure created by a difference in electrical potential

Amperage: A measure of the flow of electrical charge

CHARGE READY TRANSPORT

2 EXECUTIVE SUMMARY

4 INTRODUCTION

6 TRANSITIONING TO ELECTRICITY FOR YOUR FLEET

33 SCE'S CHARGE READY TRANSPORT PROGRAM FOR MEDIUM- AND HEAVY-DUTY VEHICLES

38 SCE'S CHARGE READY TRANSPORT ELECTRIFICATION PROCESS

44 ONGOING MAINTENANCE AND SUPPORT FOR YOUR EV CHARGING INFRASTRUCTURE

47 CONTINUING THE PROCESS

49 INTERESTED IN THE CHARGE READY TRANSPORT PROGRAM?

50 APPENDIX







55 GLOSSARY

UNDERSTANDING YOUR EVSE OPTIONS (CONTINUED)

EVSE options.

Since there is not yet a standard EV fleet charging system for all vehicles, your choice of a charging system will play a major role in determining your charging times, fleet availability, infrastructure upgrades and energy costs. Use this as a guide to help select which might work best for you.

FIGURE 12:
EVSE connection standards.

	AC	AC + DC	DC
SAE J1772	 <p>SAE J1772 AC Charging rate: up to 20 kW Supply voltage: 120/240 V/208 V Supply amperage: up to 80 A</p>	 <p>Combined Charging System (CCS Type 1) Charging rate: up to 20 kW (AC) or 350 kW (DC) Supply voltage: 480V Supply amperage: up to 500A</p>	 <p>Combined Charging System (CCS Type 1) Charging rate: up to 350 kW (DC) Supply voltage: 480 V Supply amperage: up to 500 A</p>
SAE J3068	 <p>SAE J3068 AC₆ Charging rate: up to 33 kW Supply voltage: 208-480V 3P Supply amperage: up to 160 A</p>	 <p>SAE J3068 AC₆/DC₈ Charging rate: up to 33 kW (AC) or 200 kW (DC) Supply voltage: 208-480 V 3P Supply amperage: up to 160 A (AC) or 200 A (DC)</p>	 <p>SAE J3068 DC₈ Charging rate: up to 200 kW (DC) Supply voltage: 480 V 3P Supply amperage: up to 200 A (DC)</p>
CHAdemo	N/A	N/A	 <p>CHAdemo Charging rate: up to 400 kW (DC) Supply voltage: 208-480 V 3P Supply amperage: up to 500 A</p>

UNDERSTANDING YOUR EVSE OPTIONS (CONTINUED)

FIGURE 13: EVSE equipment configurations for DC fast chargers.



WALL BOX/PEDESTAL MOUNT



STANDALONE



MODULAR SYSTEM (POWER CABINET + DISPENSER)

DC fast chargers

DC fast chargers are available in a range of sizes and power capacities, with maximum power ratings from 24 kW to over 350 kW. They are most commonly offered as wall boxes, standalone dispensers and modular systems, as shown in Figure 13. Wall box or pedestal-mounted units are typically available in the lower end of the power range, while standalone dispensers are available up to approximately 100 kW. Modular systems use one or more power cabinets to supply one or more dispensers and can supply up to 350 kW to a single dispenser, or they can split power among multiple dispensers. Keeping charging power levels below 150 kW will increase a fleet's charging options, reduce equipment and usage costs and allow greater flexibility with respect to cable lengths.

Visit www.sce.com/APL to see which charging equipment qualifies for the Charge Ready Transport program.

CHARGE READY TRANSPORT

2 EXECUTIVE SUMMARY

4 INTRODUCTION

6 TRANSITIONING TO ELECTRICITY FOR YOUR FLEET

33 SCE'S CHARGE READY TRANSPORT PROGRAM FOR MEDIUM- AND HEAVY-DUTY VEHICLES

38 SCE'S CHARGE READY TRANSPORT ELECTRIFICATION PROCESS

44 ONGOING MAINTENANCE AND SUPPORT FOR YOUR EV CHARGING INFRASTRUCTURE

47 CONTINUING THE PROCESS

49 INTERESTED IN THE CHARGE READY TRANSPORT PROGRAM?

50 APPENDIX

55 GLOSSARY

UNDERSTANDING YOUR EVSE OPTIONS (CONTINUED)

Charging examples.

Previously, we introduced examples to discuss load profiles and charging windows resulting in the following per-vehicles charging rates: 7 kW, 27.5 kW, 82.5 kW and 55 kW. The following examples illustrate how you can leverage this information to help you identify the appropriate charging interface.

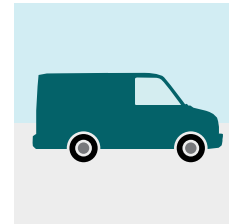

EXAMPLE 1: CITY DELIVERY VANS

Previously, we determined in Example 1 (page 14) that the per-vehicle charging rate for 10 delivery vans would be 7 kW/truck:

Per-vehicle charging rate (kW) = 70 kW ÷ 10 trucks = **7 kW/truck**

The 7 kW charging rate is well within the power range for the J1772 AC interface that is commonly used in the US. J1772 AC EVSE is available in several standard sizes as determined by common circuit breaker ratings and electrical code requirements. According to these requirements, the continuous load on a circuit should not exceed 80 percent of the circuit's rated capacity. For example, and as shown in Figure 14, a Level 2 EVSE has a maximum power draw of 32 amps on a 240-volt circuit, providing 7.7 kW of peak power and meeting the delivery van fleet's minimum charging requirements. The following formula is helpful for understanding these relationships:

$$\text{Watts} = \text{Volts} \times \text{Amps}$$

In this example, a Level 2 charger drawing power at 32 amps from a 240-volt circuit provides a charge rate of 7,680 watts, or 7.7 kW.

$$\text{Watts} = 240 \text{ volt} \times 32 \text{ amps} = 7,680 \text{ watts} \div 1,000 = 7.7 \text{ kW}$$

Although this meets the delivery van fleet's calculated charging requirement of 7 kW, it leaves little margin for error when a vehicle uses more than the average daily energy usage or has a shorter than anticipated charging window. Specifying a 9.6 kW EVSE in your design instead would provide a reasonable amount of additional margin without unnecessarily adding costs for greater electrical service capacity or EVSE capability. Networked chargers may be controlled through load management software to minimize the actual charging rate and associated costs while meeting fleet requirements.

FIGURE 14:
Common EVSE power ratings (240V) and their supporting circuits.

Common breaker size (amps)	Maximum continuous draw (amps)	Power rating (kW @ 240V)
20	16	3.8
25	20	4.8
30	24	5.8
40	32	7.7
50	40	9.6
60	48	11.5
80	64	15.4
100	80	19.2

CHARGE READY TRANSPORT

2 EXECUTIVE SUMMARY

4 INTRODUCTION

6 **TRANSITIONING TO ELECTRICITY FOR YOUR FLEET**

33 **SCE'S CHARGE READY TRANSPORT PROGRAM FOR MEDIUM- AND HEAVY-DUTY VEHICLES**

38 **SCE'S CHARGE READY TRANSPORT ELECTRIFICATION PROCESS**

44 **ONGOING MAINTENANCE AND SUPPORT FOR YOUR EV CHARGING INFRASTRUCTURE**

47 **CONTINUING THE PROCESS**

49 **INTERESTED IN THE CHARGE READY TRANSPORT PROGRAM?**

50 APPENDIX

55 GLOSSARY

UNDERSTANDING YOUR EVSE OPTIONS (CONTINUED)



EXAMPLE 2: LOCAL CLASS 8 TRUCKS (SINGLE SHIFT)

Previously, we determined in Example 2 (page 15) that a fleet of class 8 trucks running local routes on a single shift schedule would require a charging rate of 27.5 kW/truck:

$$\text{Per-vehicle charging rate (kW)} = 275 \text{ kW} \div 10 \text{ trucks} = \mathbf{27.5 \text{ kW/truck}}$$

The 27.5 kW charging rate exceeds the J1772 AC standard rating and would likely require a DC fast charger based on either the CCS-1 or CHAdeMO standard. Vehicle manufacturers will typically specify which standard is available on their vehicles, and very few manufacturers offer the option to have more than one standard on the vehicle. For this reason, the standard of your charging equipment is determined by the standard of the interface on the EVs you are purchasing. If a fleet plans to purchase a mix of vehicles using the CCS-1 and CHAdeMO standards, DC fast chargers are available with multiple cables. They can be configured to support both CCS-1 and CHAdeMO connector standards on a single dispenser.



EXAMPLE 3: LOCAL CLASS 8 TRUCKS (TWO SHIFTS)

Previously, we determined in Example 3 (page 16) that a fleet of class 8 trucks running local routes on a two-shift schedule would require two different charging rates.

$$\text{First shift per-vehicle charging rate (kW)} = 825 \text{ kW} \div 10 \text{ trucks} = \mathbf{82.5 \text{ kW/truck}}$$

$$\text{Second shift per-vehicle charging rate (kW)} = 550 \text{ kW} \div 10 \text{ trucks} = \mathbf{55 \text{ kW/truck}}$$

In a situation where the per-vehicle charging rates vary between shifts, the higher charging rate (in this example, 82.5 kW/truck) sets the minimum charging rate required from your EVSE. In other words, your charging infrastructure should be capable of delivering at least 82.5 kW per port. Both CCS-1 and CHAdeMO are viable options for this charge rate. At this power level, it is common to consider modular DC fast charging systems rather than integrated dispensers. As previously explained, modular systems connect one or more power cabinets to one or more dispensers to provide up to 350 kW, while most integrated dispensers are limited to 50-100 kW. As a two-part system, the modular option also offers more flexibility for your layout because the power cabinets can be sited at a distance from the dispensers. This is valuable at sites with significant space constraints.

FIGURE 15:
Common EVSE power ratings (480V)
and their supporting circuits.

Minimum Breaker Rating (Amps)	Maximum Continuous Draw (Amps)	Power Rating (kW @ 480V)
40	30	25
80	60	50
150	120	100
225	180	150
300	240	200
550	420	350

CHARGE READY TRANSPORT

2 EXECUTIVE SUMMARY

4 INTRODUCTION

6 TRANSITIONING TO ELECTRICITY FOR YOUR FLEET

33 SCE'S CHARGE READY TRANSPORT PROGRAM FOR MEDIUM- AND HEAVY-DUTY VEHICLES

38 SCE'S CHARGE READY TRANSPORT ELECTRIFICATION PROCESS

44 ONGOING MAINTENANCE AND SUPPORT FOR YOUR EV CHARGING INFRASTRUCTURE

47 CONTINUING THE PROCESS

49 INTERESTED IN THE CHARGE READY TRANSPORT PROGRAM?

50 APPENDIX

55 GLOSSARY

UNDERSTANDING YOUR EVSE OPTIONS (CONTINUED)

EVSE selection takeaways.

The following are points to consider when selecting EVSE for your fleet application:

- AC chargers are less expensive than DC chargers for the same power level and are supplied by 240-volt single-phase or 208-volt three-phase circuits commonly available in most commercial facilities. Where AC charging is sufficient for your fleet's needs, it is generally the most cost-effective option.
- Specifying EVSE power ratings that are greater than the calculated average required charging rate will help avoid incomplete charging cycles. Regardless of your charging rate, most batteries currently available in EVs charge more slowly when they are nearly depleted or nearly full.
- Keeping charging power levels below 150 kW will increase your DC charging equipment options, reduce equipment and electricity costs and allow greater flexibility with respect to cable lengths.
- Rightsizing (neither under- nor oversizing) your charging scenario for your fleet's specific application may also optimize the lifetime of your EV's battery and energy storage system.
- Ambient temperature affects EV charging rates and range. Fleets that may operate in cold environments with sustained average daily temperatures at or below freezing should account for the impact of extended charging times and shorter vehicle ranges on charging windows during seasonal cold periods.

CHARGE READY TRANSPORT

2 EXECUTIVE SUMMARY

4 INTRODUCTION

6 **TRANSITIONING TO ELECTRICITY FOR YOUR FLEET**

33 SCE'S CHARGE READY TRANSPORT PROGRAM FOR MEDIUM- AND HEAVY-DUTY VEHICLES

38 SCE'S CHARGE READY TRANSPORT ELECTRIFICATION PROCESS

44 ONGOING MAINTENANCE AND SUPPORT FOR YOUR EV CHARGING INFRASTRUCTURE

47 CONTINUING THE PROCESS

49 INTERESTED IN THE CHARGE READY TRANSPORT PROGRAM?

50 APPENDIX

55 GLOSSARY

COST GUIDELINES AND FUNDING SOLUTIONS FOR YOUR EVSE

While EVSE costs vary by vendor, order size and level of sophistication, average EVSE price ranges in Figure 16 are useful benchmarks for estimating your capital cost, exclusive of electrical infrastructure upgrades. Electrical infrastructure upgrade costs may range from a few hundred to a few thousand dollars for lower-power EVSE to tens of thousands for higher-power EVSE and are ultimately site-specific. If you contact the SCE EV Support Team early on in your consideration process, they can help guide you toward vehicle manufacturers as well as help evaluate your site to determine the infrastructure support that may be needed. In addition, depending on your vehicle type and location, SCE has incentives and rebates to help absorb upfront infrastructure costs.

The SCE Charge Ready Transport program supports Level 2 and DC fast chargers in a variety of installation configurations to meet your needs. You are responsible for procuring the chargers and having them installed. You can select EVSE options from our [Approved Product List](#).

The power level ranges presented cover the standard offerings and are based on 2019 data. Costs do not include extended warranties, maintenance service contracts or recurring subscription fees. There are currently few standard DC fast charge offerings between 30 kW and 50 kW.

FIGURE 16:
Per unit EVSE average cost ranges by power level and networkability.

Charging type	Power level	Networkable	Price range (\$)
Level 2 AC	<8 kW	No	\$500-\$1,000
Level 2 AC	10-20 kW	No	\$700-\$1,500
Level 2 AC	<8 kW	Yes	\$500-\$1,000
Level 2 AC	10-20 kW	Yes	\$3,000-\$6,500
Level 2 DC	20-30 kW	Yes	\$10,000-\$40,000
Level 2 DC	50-150 kW	Yes	\$50,000-\$100,000
Level 2 DC	>150 kW	Yes	\$150,000+



Please see [SCE program details](#) starting on page 34.

Charge Ready Transport supports Level 2 and DC fast chargers. Go to www.sce.com/APL for a list of vendors.

CHARGE READY TRANSPORT

2 EXECUTIVE SUMMARY

4 INTRODUCTION

6 TRANSITIONING TO ELECTRICITY FOR YOUR FLEET

33 SCE'S CHARGE READY TRANSPORT PROGRAM FOR MEDIUM- AND HEAVY-DUTY VEHICLES

38 SCE'S CHARGE READY TRANSPORT ELECTRIFICATION PROCESS

44 ONGOING MAINTENANCE AND SUPPORT FOR YOUR EV CHARGING INFRASTRUCTURE

47 CONTINUING THE PROCESS

49 INTERESTED IN THE CHARGE READY TRANSPORT PROGRAM?

50 APPENDIX

55 GLOSSARY

NETWORKING AND CLOUD-BASED SERVICES FOR YOUR EVSE

EVSE vendors may offer a networking service using a cabled or wireless Internet connection, as well as an additional cloud-based communications platform. These services are valuable to fleet managers who need to collect more activity data from their EVSE than what is reported on their monthly utility bill. Networking allows EVSE owners to monitor charging activity and detect failures in real time over a desktop or mobile device.

Additional functionality, including payment collection and user interface, can be added with a cloud-based communications service (Figure 17). Most EVSEs use the Open Charge Point Protocol (OCPP), making them compatible with most network providers, but some effort may be required for integration. EVSE that use only proprietary communications protocols are likely to only communicate with the EVSE vendor's network services, restricting the fleet's choices for selecting other network providers.

FIGURE 17: Cloud-based services allow fleet managers, EVSE vendors and EVSE users to share data and even payments over a wireless connection. Networked EVSE allow fleet managers to collect a smaller set of data from their EVSE.

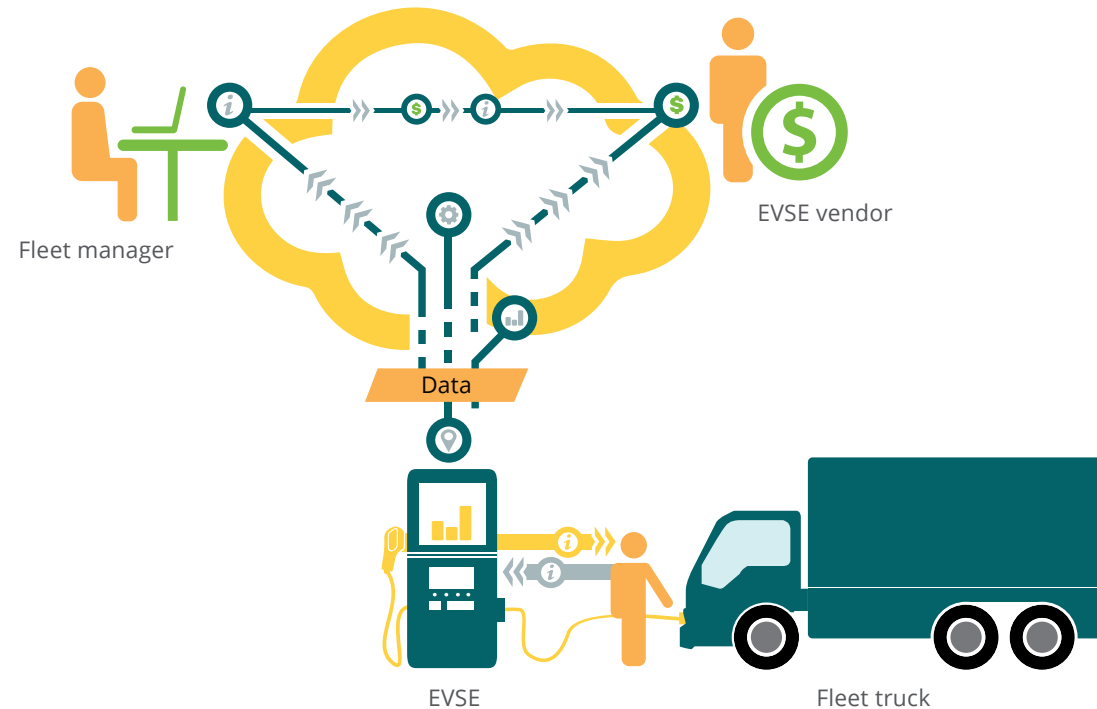

TERMS YOU NEED TO KNOW

Networking service: An Internet-based service that allows an EVSE owner to analyze basic activity data from one or more EVSE

Cloud-based communications: A wireless Internet-based service carrying information on EVSE status, energy consumption, location and payments for use between the owner and the user(s)

CHARGE READY TRANSPORT

2 EXECUTIVE SUMMARY

4 INTRODUCTION

6 **TRANSITIONING TO ELECTRICITY FOR YOUR FLEET**

33 SCE'S CHARGE READY TRANSPORT PROGRAM FOR MEDIUM- AND HEAVY-DUTY VEHICLES

38 SCE'S CHARGE READY TRANSPORT ELECTRIFICATION PROCESS

44 ONGOING MAINTENANCE AND SUPPORT FOR YOUR EV CHARGING INFRASTRUCTURE

47 CONTINUING THE PROCESS

49 INTERESTED IN THE CHARGE READY TRANSPORT PROGRAM?

50 APPENDIX

55 GLOSSARY

NETWORKING AND CLOUD-BASED SERVICES FOR YOUR EVSE (CONTINUED)

Most EVSE vendors offer networking and cloud-based services for an up-front cost plus a monthly fee. It is important to consider these costs as well as the reliability of Internet and cellular service in your area. While EVSE vendors provide the software for networked or cloud-based communications, their software's reliability depends on the quality of your Internet connection. If you've determined that networking or cloud-based communications are a good fit for your business, and your EVSE project's success depends on that connection, then it is important to review contingency plans in the event of less than 100 percent reliability from your Internet service provider. If you are using grant funds for your EVSE, you may want to find out whether the grant's reporting requirements include data from a cloud-based communications platform, and plan accordingly. Additionally, to participate in SCE's Charge Ready Transport program, you are required to provide EVSE usage data for a minimum of five years.

Another resource for tracking vehicle charging may be your EV manufacturer. Some manufacturers offer charging management systems onboard their vehicles, which may produce sufficient information for some fleets.

Charge Ready Transport program participants agree to maintain a networking service and EVSE usage data for five years.

CHARGE READY TRANSPORT



SCE'S CHARGE READY TRANSPORT PROGRAM FOR MEDIUM- AND HEAVY-DUTY VEHICLES

While transitioning a vehicle fleet to electric can offer significant total cost of ownership savings over the long term, upfront costs to procure new EVs and install chargers can be high for many businesses. To help mitigate these upfront costs, SCE created the Charge Ready Transport program which provides no- to low-cost infrastructure and EV charging station rebates.

Here's how the Charge Ready Transport program works.

The Charge Ready Transport Program provides the infrastructure to support the installation of EV charging equipment at low- to no-cost to the program participant.³ This presents a unique opportunity for those fleet operators that choose to acquire EVs because, as discussed, the infrastructure required to support the installation of EV charging equipment typically represents a sizable investment.

Through this program, SCE will design, construct and install the necessary infrastructure on both the utility side and customer side of the electric meter. Participants are, however, responsible for the selection, purchase and installation of the EV charging equipment. In addition to receiving the

necessary infrastructure to support EV charging equipment, this program also provides two additional rebate options, which are subject to other requirements.

The Charging Equipment Rebate is offered to eligible participants in order to offset a portion of the costs associated with the purchase of the charging equipment. The Charging Equipment Rebate is only available to those who install charging equipment at a project site that is located in a designated Disadvantaged Community (DAC) where the customer is NOT listed as a Fortune 1000 company,⁴ or to those acquiring and operating school buses or transit buses anywhere in SCE's service territory. In all cases, to be eligible

for the Charging Equipment Rebate, charging equipment must be selected from SCE's **Approved Product List**.

The second rebate option offered through this program is referred to as the Make-Ready Rebate. This rebate option is available to any participant who chooses to design, procure and install the customer side of the meter infrastructure work. The Make-Ready Rebate is intended to offset up to 80 percent of the costs that SCE would otherwise incur for performing that work. Every participant will have the choice to perform this work themselves and receive the rebate, or to have SCE perform the work at no cost to the customer.⁵

³All work and facilities necessary for participation in this Program, as determined by SCE, in SCE's sole discretion and in accordance with its applicable tariffs and design standards, including utility distribution infrastructure (e.g., any new transformers, services, and meters) and infrastructure installed by SCE on the participant's side of the meter (e.g., any new panels, stepdown transformers, conduits, wires, connectors, and any other hardware installed as part of this program), excluding the purchase and installation of the actual EV charging equipment.

⁴The Fortune 1000 list is produced annually and includes the 1000 largest companies measured by revenue, compiled and published by Fortune Magazine.

⁵Customer must receive approval to participate in Charge Ready Transport Program prior to beginning any construction.

CHARGE READY TRANSPORT

2 EXECUTIVE SUMMARY

4 INTRODUCTION

6 TRANSITIONING TO ELECTRICITY FOR YOUR FLEET

33 SCE'S CHARGE READY TRANSPORT PROGRAM FOR MEDIUM- AND HEAVY-DUTY VEHICLES

38 SCE'S CHARGE READY TRANSPORT ELECTRIFICATION PROCESS

44 ONGOING MAINTENANCE AND SUPPORT FOR YOUR EV CHARGING INFRASTRUCTURE

47 CONTINUING THE PROCESS

49 INTERESTED IN THE CHARGE READY TRANSPORT PROGRAM?

50 APPENDIX

55 GLOSSARY

SCE'S CHARGE READY TRANSPORT PROGRAM FOR MEDIUM- AND HEAVY-DUTY VEHICLES (CONTINUED)

As illustrated in Figure 18, the utility side of the meter infrastructure work includes all infrastructure from SCE's distribution system to a new circuit panel that will be installed to support EV charging. This segment of work is also referred to as the utility-side make-ready. SCE will always be responsible for designing, procuring, installing and maintaining the necessary infrastructure located on the utility side of the meter.

FIGURE 18: Charge Ready Transport program - infrastructure delineation.

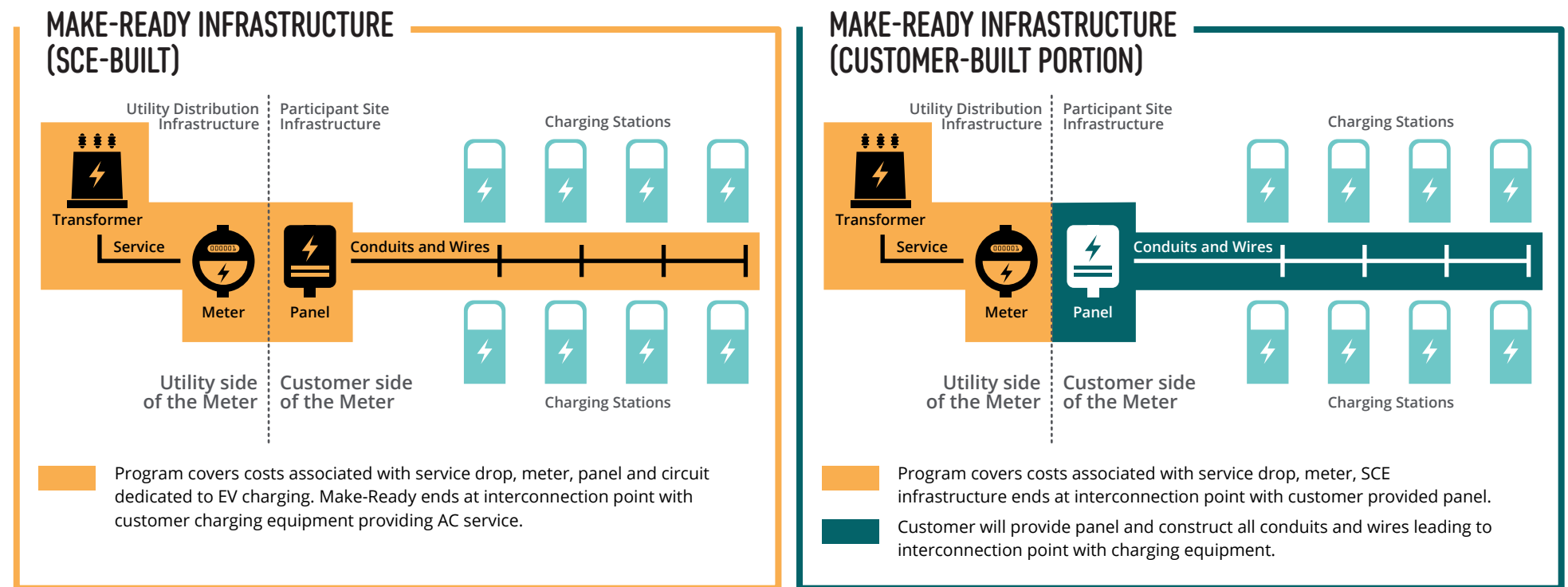

CHARGE READY TRANSPORT

2 EXECUTIVE SUMMARY

4 INTRODUCTION

6 TRANSITIONING TO ELECTRICITY FOR YOUR FLEET

33 SCE'S CHARGE READY TRANSPORT PROGRAM FOR MEDIUM- AND HEAVY-DUTY VEHICLES

38 SCE'S CHARGE READY TRANSPORT ELECTRIFICATION PROCESS

44 ONGOING MAINTENANCE AND SUPPORT FOR YOUR EV CHARGING INFRASTRUCTURE

47 CONTINUING THE PROCESS

49 INTERESTED IN THE CHARGE READY TRANSPORT PROGRAM?

50 APPENDIX

55 GLOSSARY

SCE'S CHARGE READY TRANSPORT PROGRAM FOR MEDIUM- AND HEAVY-DUTY VEHICLES (CONTINUED)

In addition to Figure 19, there may be times when a customer chooses to go with a modular DC system. In this scenario, SCE will only provide power to the power cabinet (charger electronics) and the customer will be responsible for the infrastructure from the power cabinet to the dispensers.

Included with the utility-side infrastructure work, SCE will set an interval data recording (IDR) meter to capture EV charging equipment consumption data. The meter will track usage in 15-minute increments, and may also be used for billing purposes.

The next segment of work involves the infrastructure to be located on the customer side of the meter. This work includes all infrastructure from the new panel that will be set as part of the utility-side infrastructure work, up to the first point of interconnection with the customer's EV charging equipment. Customers will have the option to have SCE perform the customer-side infrastructure work (also referred to as the customer-side make-ready) at no cost. Alternatively, customers may choose to design, procure, install and maintain the customer-side make-ready infrastructure themselves. If the customer chooses to perform this work and meets all other program requirements, they will be eligible for the Make-Ready Rebate.

FIGURE 19: Centralized charger electronics with modular DC power distribution.

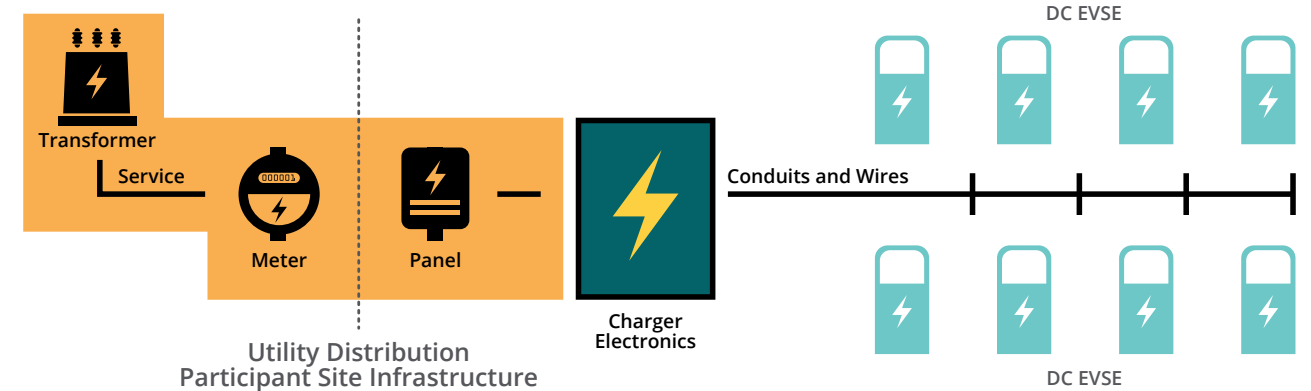

Program covers costs associated with service drop, meter, panel and circuit dedicated to EV charging. Make-Ready ends at interconnection point with customer charging equipment providing AC service.

CHARGE READY TRANSPORT

2 EXECUTIVE SUMMARY

4 INTRODUCTION

6 TRANSITIONING TO ELECTRICITY FOR YOUR FLEET

33 SCE'S CHARGE READY TRANSPORT PROGRAM FOR MEDIUM- AND HEAVY-DUTY VEHICLES

38 SCE'S CHARGE READY TRANSPORT ELECTRIFICATION PROCESS

44 ONGOING MAINTENANCE AND SUPPORT FOR YOUR EV CHARGING INFRASTRUCTURE

47 CONTINUING THE PROCESS

49 INTERESTED IN THE CHARGE READY TRANSPORT PROGRAM?

50 APPENDIX

55 GLOSSARY

SCE'S CHARGE READY TRANSPORT PROGRAM FOR MEDIUM- AND HEAVY-DUTY VEHICLES (CONTINUED)

The last segment of work includes the actual installation of EV charging equipment. Customers will always be responsible for selecting, procuring and installing the EV charging equipment. If the equipment selected is listed on SCE's Approved Product List (APL) and the participant meets the Charging Equipment Rebate eligibility requirements, the customer will receive the Charging Equipment Rebate.

SCE will work closely with participants to help inform their decision-making and provide guidance throughout the complex infrastructure selection and deployment process while attempting to meet their operational needs balanced with managing potential grid impacts.

Go to www.sce.com/CRT to see a video overview of the program.

Charge Ready Transport program eligibility requirements.



Be an SCE customer.



Provide data related to charger usage for a minimum of five years.



Provide a property easement as needed.



Commit to procuring a minimum of two electric fleet vehicles or converting at least two fossil-fueled vehicles to electric.



Own or lease the property where chargers are installed.



Agree to program terms and conditions.



Operate and maintain chargers for a minimum of 10 years.

Eligible vehicles include: medium- and heavy-duty trucks, shuttles and vans, school buses, transit buses, transportation refrigeration units, airport ground support equipment, port equipment, forklifts and other off-road equipment.

CHARGE READY TRANSPORT



SCE Charge Ready Transport electrification process.



CHARGE READY TRANSPORT

2 EXECUTIVE SUMMARY

4 INTRODUCTION

6 TRANSITIONING TO ELECTRICITY FOR YOUR FLEET

33 SCE'S CHARGE READY TRANSPORT PROGRAM FOR MEDIUM- AND HEAVY-DUTY VEHICLES

38 SCE'S CHARGE READY TRANSPORT ELECTRIFICATION PROCESS

44 ONGOING MAINTENANCE AND SUPPORT FOR YOUR EV CHARGING INFRASTRUCTURE

47 CONTINUING THE PROCESS

49 INTERESTED IN THE CHARGE READY TRANSPORT PROGRAM?

50 APPENDIX

55 GLOSSARY

SCE CHARGE READY TRANSPORT ELECTRIFICATION PROCESS

Consult with SCE early to identify the best solution for your needs.

Your vehicle and charging needs will drive site design and electrical requirements. The SCE EV Support Team is here to lend their expertise, from recommending vehicles and charging equipment manufacturers to reviewing logistical considerations and your site designs. They can also help with solution design through construction execution. By partnering with you and your team, SCE can make the electrification process move as quickly and smoothly as possible.

The illustration on the following page shows the approximate timing, collaboration and responsibilities of those involved in the design, permitting and execution of the electrification process.



It's never too early.

Submit an interest form to get in touch with a SCE EV Support Team member who can discuss the program in detail: www.sce.com/CRTform

CHARGE READY TRANSPORT

2 EXECUTIVE SUMMARY

4 INTRODUCTION

6 TRANSITIONING TO ELECTRICITY FOR YOUR FLEET

33 SCE'S CHARGE READY TRANSPORT PROGRAM FOR MEDIUM- AND HEAVY-DUTY VEHICLES

38 SCE'S CHARGE READY TRANSPORT ELECTRIFICATION PROCESS

44 ONGOING MAINTENANCE AND SUPPORT FOR YOUR EV CHARGING INFRASTRUCTURE

47 CONTINUING THE PROCESS

49 INTERESTED IN THE CHARGE READY TRANSPORT PROGRAM?

50 APPENDIX

55 GLOSSARY

SCE CHARGE READY TRANSPORT ELECTRIFICATION PROCESS (CONTINUED)

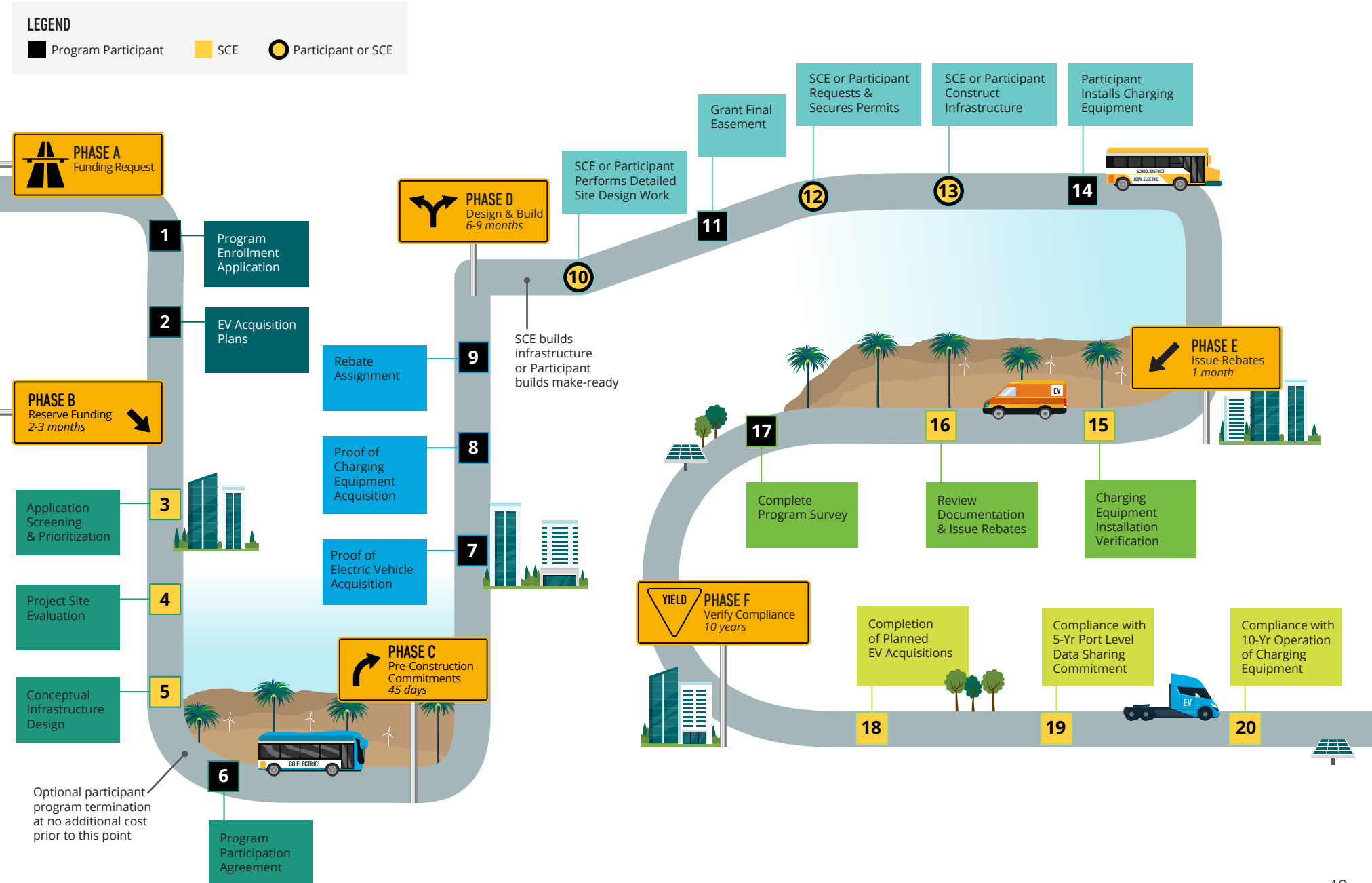

CHARGE READY TRANSPORT

2 EXECUTIVE SUMMARY

4 INTRODUCTION

6 TRANSITIONING TO ELECTRICITY FOR YOUR FLEET

33 SCE'S CHARGE READY TRANSPORT PROGRAM FOR MEDIUM- AND HEAVY-DUTY VEHICLES

38 SCE'S CHARGE READY TRANSPORT ELECTRIFICATION PROCESS

44 ONGOING MAINTENANCE AND SUPPORT FOR YOUR EV CHARGING INFRASTRUCTURE

47 CONTINUING THE PROCESS

49 INTERESTED IN THE CHARGE READY TRANSPORT PROGRAM?

50 APPENDIX

55 GLOSSARY

CONCEPTUAL DESIGN FOR YOUR EV CHARGING INFRASTRUCTURE

Deciding where to site and install charging infrastructure to accommodate your new EV fleet requires planning to optimize location, operations and logistics. In California, you must notify your utility of any electrical additions or upgrades at your facility regardless of the scope or scale.

When working with SCE, it is good practice to engage early. We can be particularly helpful once you have determined your on-site energy needs and existing electrical equipment's capacity (see Choosing the right EV charging infrastructure for your fleet) or sooner if you need guidance. Once notified, SCE will advise if the current service meets your new electricity needs or if infrastructure upgrades are required.

When you partner with SCE from the beginning of your process, SCE can advise you of available incentives and charger rebates and help to design your project up to the charging station. Plus, you'll have access to resources, assistance and information that can significantly reduce the time and cost of your infrastructure upgrades. For example, we can often help reduce infrastructure costs associated with connection to SCE distribution circuits simply by identifying where on your property is the shortest distance to an interconnection point with available electric capacity.

FIGURE 20: Electrical equipment layout at a charging depot.

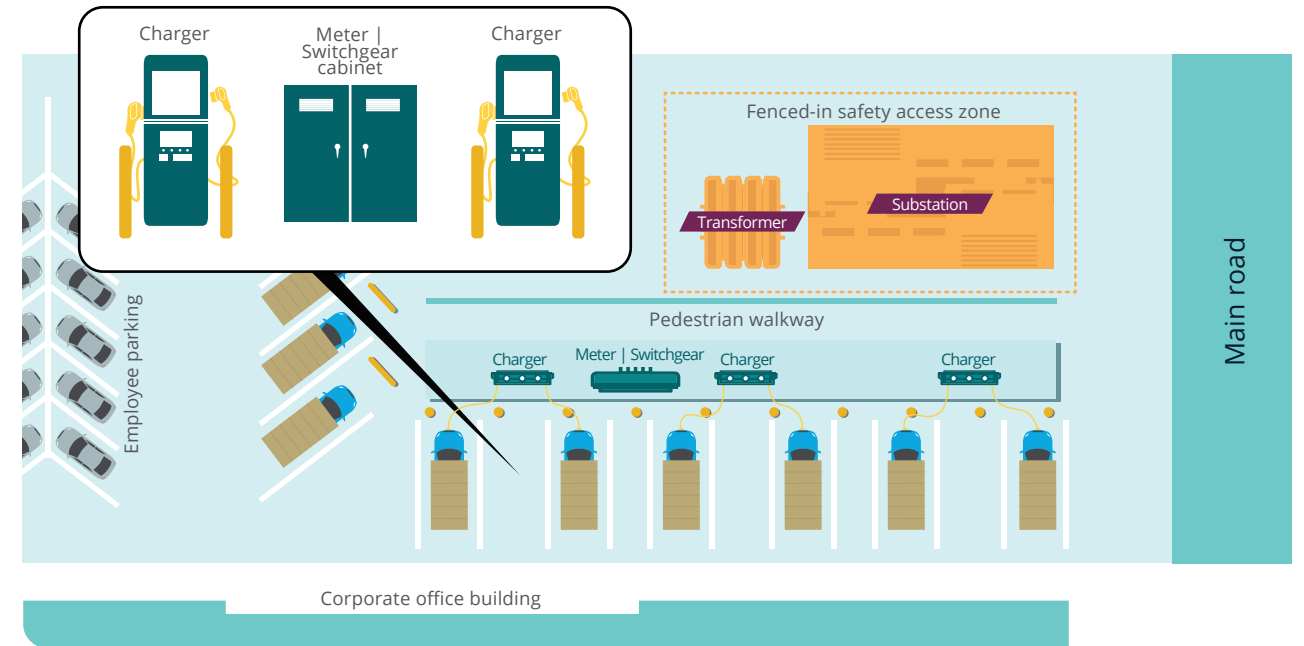

When assessing your site, safety is our top priority and it is important to consider not just the entry, park and exit pathways but also the vertical surfaces, protected areas and locations of existing electrical equipment. Using existing surfaces can reduce capital costs by eliminating the need for a dedicated EVSE post and in-ground wiring. However, if the space between vehicles and the wall serves as a walkway, then stretching EVSE cords across that space could create a hazard that forces pedestrians to walk through more exposed parts of your lot. (See Figure 20.)

CHARGE READY TRANSPORT

2 EXECUTIVE SUMMARY

4 INTRODUCTION

6 TRANSITIONING TO ELECTRICITY FOR YOUR FLEET

33 SCE'S CHARGE READY TRANSPORT PROGRAM FOR MEDIUM- AND HEAVY-DUTY VEHICLES

38 SCE'S CHARGE READY TRANSPORT ELECTRIFICATION PROCESS

44 ONGOING MAINTENANCE AND SUPPORT FOR YOUR EV CHARGING INFRASTRUCTURE

47 CONTINUING THE PROCESS

49 INTERESTED IN THE CHARGE READY TRANSPORT PROGRAM?

50 APPENDIX

55 GLOSSARY

CONCEPTUAL DESIGN FOR YOUR EV CHARGING INFRASTRUCTURE (CONTINUED)

Questions to ask when developing your design.

Your SCE EV Support Team will work with you to find the optimum solution for your charging and electrification needs. On your path to signing a contract, we'll likely use many of the following questions to help guide the design process:

Question	Points of assessment
What are your fleet's parking logistics and other operational characteristics at the depot?	<ul style="list-style-type: none"> • Parking location—daytime, overnight • Parking duration—daytime, overnight • Vehicle requirements—turn radius, cargo transfer, washing
What existing surfaces, structures or spaces will support the EVSE that you plan to procure?	<ul style="list-style-type: none"> • Wall, bollard or overhead features' proximity to current and potential vehicle parking locations • Wall, bollard or overhead features' proximity to your electrical equipment • Level of EVSE exposure to moving vehicles or other hazards
Can your existing electrical equipment support your expected maximum load?	<ul style="list-style-type: none"> • Transformer and electrical panel capacity ratings • Utility supply
What areas are commonly used for pedestrian activity?	<ul style="list-style-type: none"> • EVSE hazards to current pedestrian activity • Pedestrian activity as a hazard to EVSE layout
Will you need new electrical services?	<ul style="list-style-type: none"> • Source of utility power (underground facilities for trenching or boring) • Power level: secondary or primary, transmission • Transformer location for stepping down power to meet EVSE voltage requirements



TERMS YOU NEED TO KNOW

Transmission: The process of moving power in large quantities across long distances

Substation: A set of electric equipment that reduces high-voltage power to a voltage suitable for customer use

CHARGE READY TRANSPORT

2 EXECUTIVE SUMMARY

4 INTRODUCTION

6 TRANSITIONING TO ELECTRICITY FOR YOUR FLEET

33 SCE'S CHARGE READY TRANSPORT PROGRAM FOR MEDIUM- AND HEAVY-DUTY VEHICLES

38 SCE'S CHARGE READY TRANSPORT ELECTRIFICATION PROCESS

44 ONGOING MAINTENANCE AND SUPPORT FOR YOUR EV CHARGING INFRASTRUCTURE

47 CONTINUING THE PROCESS

49 INTERESTED IN THE CHARGE READY TRANSPORT PROGRAM?

50 APPENDIX

55 GLOSSARY

EXECUTION TIMELINES

An EVSE electrification project duration depends on a variety of factors. However, in SCE's experience, the engineered design phase can take three to five months or more. The construction phase may take between six weeks and six months or more, depending on the project scope. A small project with no infrastructure upgrades may only require utility notification. However, projects that fit the scope of SCE's Charge Ready Transport program require analysis, site inspections, construction and collaboration to produce an optimal solution.

Construction timelines on your property will depend on your site design and chosen vendors. If electrical work is required, which is usually the case with any new electrification of a fleet, then the construction period may extend over several months or longer. The type of EVSE you choose will also play a role in estimating timelines. Currently, a growing number of vendors offer Level 2 EVSE as an off-the-shelf product with efficient installation, while fewer vendors sell DC fast chargers. A lower-power EVSE may also require fewer infrastructure upgrades than a DC fast charger. SCE or your electrical contractor and EVSE vendor can advise on timelines and, if appropriate, how delivery and construction can be staggered to minimize disruption to your existing operations.

Finally, the planning and construction for a transformer upgrade is typically a three-month job. Still, larger projects requiring new equipment such as cabling and substation modifications may require six to eight months or more. This work usually occurs concurrently with other work.

GET IN TOUCH



Your SCE Account Manager is your go-to contact for everything EV. If you don't yet have an Account Manager assigned, [start here](#).

CHARGE READY TRANSPORT

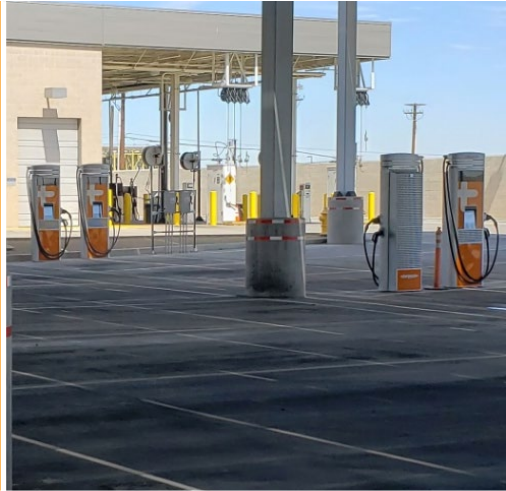
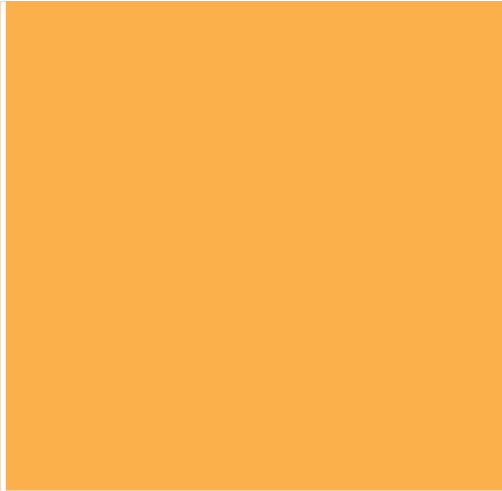

Ongoing maintenance and support for your EV charging infrastructure.



ONGOING MAINTENANCE AND SUPPORT FOR YOUR EV CHARGING INFRASTRUCTURE

MAINTAINING YOUR EVSE

FIGURE 21:
Anatomy of an EVSE.

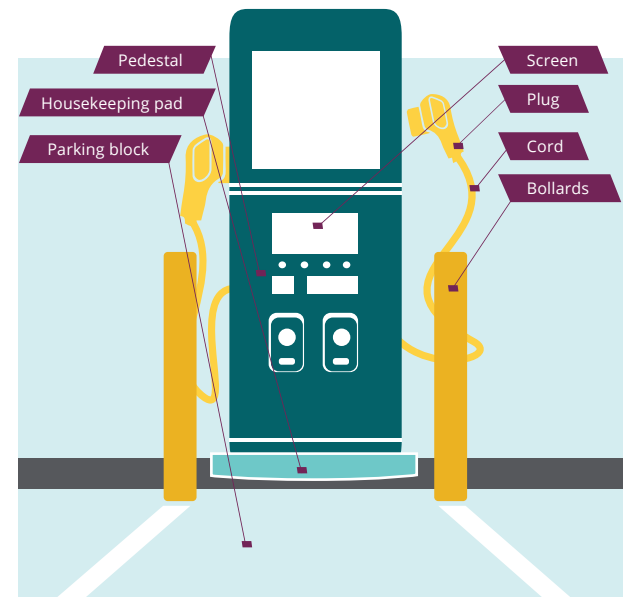

Performing maintenance on your EVSE is generally considered simpler than maintaining diesel and gas fueling equipment. Still, maintaining your EVSE will initially involve unfamiliar components and procedures, which may require new training, knowledge and skills.

Fleets can significantly reduce EVSE maintenance by incorporating preventive designs into site planning. During the design stage, ask prospective EVSE vendors about the following measures:

- **Housekeeping pads:** Installing these under EVSE posts can limit exposure to heavy rain, snow and dust.
- **Screen protection:** Using protected screens that are oriented away from direct sun exposure minimizes overheating, avoiding malfunctions.
- **Collision protection:** Installing bollards and clear signage can protect the EVSE from accidental vehicle collision, particularly in poor-visibility conditions.
- **Cord length:** Using shorter cords and/or cord controls to securely store cords when not in use limits your EVSE cord's exposure to moving vehicles and people.
- **Cord management:** Safely storing cords on EVSE dispensers or using cord retractors when not in use will increase safety and reduce the chances of damaging equipment.

CHARGE READY TRANSPORT

2 EXECUTIVE SUMMARY

4 INTRODUCTION

6 TRANSITIONING TO ELECTRICITY FOR YOUR FLEET

33 SCE'S CHARGE READY TRANSPORT PROGRAM FOR MEDIUM- AND HEAVY-DUTY VEHICLES

38 SCE'S CHARGE READY TRANSPORT ELECTRIFICATION PROCESS

44 ONGOING MAINTENANCE AND SUPPORT FOR YOUR EV CHARGING INFRASTRUCTURE

47 CONTINUING THE PROCESS

49 INTERESTED IN THE CHARGE READY TRANSPORT PROGRAM?

50 APPENDIX

55 GLOSSARY

MAINTAINING YOUR EVSE (CONTINUED)

Once your EVSE is up and running, incorporating the following best practices into your regular maintenance schedule can help maximize your EVSE's useful life. You can enlist the help of your EVSE vendor to understand and implement these practices:

Best practices.

- Turn off the power to your EVSE equipment before conducting maintenance.
- Routinely inspect cords, plugs and cord storage devices for wear and tear or misuse.
- For DC fast chargers, inspect air conditioning or other cooling filters for clogs or buildup.
- Inspect area surrounding the EVSE for changes that could compromise the equipment's integrity, such as cracked pavement, flooding, access barriers or compromised building structures (for wall-mounted EVSE).
- Review data reports for unusual results or other signs of error in the network or cloud-based communications platform.
- Compare EVSE data with your utility bills to confirm that the equipment is functioning as intended.

Most EVSE vendors currently offer three-year, five-year and 10-year warranties on their equipment. As a participant in the SCE Charge Ready Transport program, you agree to maintain your equipment for 10 years, so you may want a warranty to cover the full 10 years. The warranty on these features may be separate, if you are purchasing network and/or cloud-based communications services. Ask your EVSE vendor to clearly explain what components of your EVSE are covered under warranties and their time frame.

As part of the Charge Ready Transport program, SCE will maintain the SCE constructed portion of all the electrical infrastructure (i.e. pole to the charging station) unless you elect to construct and maintain the infrastructure from the customer side of the meter (i.e. the panel to the charging station).

CHARGE READY TRANSPORT



Continuing
the process.



CONTINUING THE PROCESS

The state of California has set clear goals to increase the numbers of EVs in medium- and heavy-duty fleets by the year 2030 and beyond. The SCE Charge Ready Transport program has set a goal of establishing more than 870 sites supporting 8,490 EVs. Meeting these goals will require significant expansion in the number of EVSE across the state.

Your first project to set up EV charging to electrify your fleet will likely be the most time-intensive. You will probably find that subsequent projects—whether electrifying more vehicles at the same location or expanding to new facilities—become more efficient through established relationships. In any case, following best practices will help you achieve the greatest success:

Best practices.

- **Notify SCE early when you anticipate your transportation electrification needs may change.** Not only are you required to notify any utility in California of an increase in expected load, but SCE can be a valuable resource for discovering new equipment solutions and cost-saving opportunities. Take advantage of SCE's Charge Ready Transport program.
- **Know your fleet vehicle requirements.** Understand your fleet's charging and logistical needs so you can clearly communicate and build everything to support these requirements.
- **Faster is not always better.** Consider the cost and benefit tradeoffs of all charging scenarios and rate structures.
- **Plan for the future.** Design your layout and electrical infrastructure today to support your fleet's needs of tomorrow, minimizing future construction and connection costs.
- **Leverage available support.** Contact your SCE Account Manager or the EV Support Team to get started on your EV journey.



Look for funding.

EVSE-supportive programs exist from a variety of sources and will continue to evolve. Track the programs relevant to your business for right-sized opportunities.

CHARGE READY TRANSPORT

2 EXECUTIVE SUMMARY

4 INTRODUCTION

6 TRANSITIONING TO ELECTRICITY FOR YOUR FLEET

33 SCE'S CHARGE READY TRANSPORT PROGRAM FOR MEDIUM- AND HEAVY-DUTY VEHICLES

38 SCE'S CHARGE READY TRANSPORT ELECTRIFICATION PROCESS

44 ONGOING MAINTENANCE AND SUPPORT FOR YOUR EV CHARGING INFRASTRUCTURE

47 CONTINUING THE PROCESS

49 INTERESTED IN THE CHARGE READY TRANSPORT PROGRAM?

50 APPENDIX

55 GLOSSARY

INTERESTED IN THE CHARGE READY TRANSPORT PROGRAM?

Ready to learn more about your eligibility for the Charge Ready Transport program and next steps to electrify your fleet? Start now. Reach out to your Account Manager or [sign up online](#) to get connected.

[SIGN UP](#)



CHARGE READY TRANSPORT



Appendix



2 EXECUTIVE SUMMARY

4 INTRODUCTION

6 TRANSITIONING TO ELECTRICITY FOR YOUR FLEET

33 SCE'S CHARGE READY TRANSPORT PROGRAM FOR MEDIUM- AND HEAVY-DUTY VEHICLES

38 SCE'S CHARGE READY TRANSPORT ELECTRIFICATION PROCESS

44 ONGOING MAINTENANCE AND SUPPORT FOR YOUR EV CHARGING INFRASTRUCTURE

47 CONTINUING THE PROCESS

49 INTERESTED IN THE CHARGE READY TRANSPORT PROGRAM?

50 APPENDIX

55 GLOSSARY

APPENDIX

The Funding Finder Tool.

The **Funding Finder Tool** is designed to help you search and filter for medium- and heavy-duty EV and infrastructure programs in California. Please note that for the most accurate and up-to-date information about each program, you should visit the funding agency's website or speak with the agency directly.

The Low Carbon Fuel Standard program.

Under California's Low Carbon Fuel Standard (LCFS) program, EV fleet owners may be eligible to earn carbon credits with the energy dispensed to charge EVs. LCFS credits can then be sold at a market-determined price. Current credit prices equate to \$0.20-\$0.30/kWh for medium- and heavy-duty vehicles.⁶ Eligibility depends on several factors, including proof that the energy reported is only used to power EVs. In many cases, a dedicated meter, like the one provided through SCE's Charge Ready Transport Program, offers the most reliable and lowest-cost data source.

⁶Monthly LCFS Credit Transfer Activity Reports, California Air Resources Board:
<https://ww3.arb.ca.gov/fuels/lcfs/credit/lrtmonthlycreditreports.htm>

CHARGE READY TRANSPORT

2 EXECUTIVE SUMMARY

4 INTRODUCTION

6 TRANSITIONING TO ELECTRICITY FOR YOUR FLEET

33 SCE'S CHARGE READY TRANSPORT PROGRAM FOR MEDIUM- AND HEAVY-DUTY VEHICLES

38 SCE'S CHARGE READY TRANSPORT ELECTRIFICATION PROCESS

44 ONGOING MAINTENANCE AND SUPPORT FOR YOUR EV CHARGING INFRASTRUCTURE

47 CONTINUING THE PROCESS

49 INTERESTED IN THE CHARGE READY TRANSPORT PROGRAM?

50 APPENDIX

55 GLOSSARY

THE ELECTRIC GRID: AN OVERVIEW

By understanding the basics of how electricity is generated, transported and sold, you can make better decisions regarding your electrical usage and costs—and understand why electricity as a fuel source might be an advantage over your existing gas and diesel fleets.

This becomes especially important as you increase your electrical usage to accommodate a much higher demand. The following section will provide an overview of the electrical grid and the role it may play in your EV transition and ongoing operations.

In the simplest terms, electricity is the flow of electrical charge. Electricity powers a wide array of essential electrical devices. The electric grid is the interconnected group of power lines and associated equipment that delivers electric energy to consumers from where it is generated (at high voltage) to where it is consumed (usually at much lower voltage).

SCE's electric grid consists of transmission lines supported by countless subsystems and components. Using this complex system, SCE can generate, procure and distribute electricity. To continually ensure that customers receive reliable and affordable electricity, we must carefully manage and maintain portions of the grid within the service territory.

The grid carries electric power, as measured in watts or joules per second. This refers to the rate at which electric energy is (or can be) consumed in an electrical circuit. The grid is a massive, far-reaching infrastructure that has been called the largest machine in the world. This "machine" draws on a plethora of different sources of power and connects those sources to the countless devices that turn that power into useful work.

The following sections describe key steps in producing electric power and delivering it to users through the grid. They provide basic information to better understand how electric power reaches consumers for use in electrical equipment ranging from light bulbs to electric vehicles and everything in between.

CHARGE READY TRANSPORT

2 EXECUTIVE SUMMARY

4 INTRODUCTION

6 TRANSITIONING TO ELECTRICITY FOR YOUR FLEET

33 SCE'S CHARGE READY TRANSPORT PROGRAM FOR MEDIUM- AND HEAVY-DUTY VEHICLES

38 SCE'S CHARGE READY TRANSPORT ELECTRIFICATION PROCESS

44 ONGOING MAINTENANCE AND SUPPORT FOR YOUR EV CHARGING INFRASTRUCTURE

47 CONTINUING THE PROCESS

49 INTERESTED IN THE CHARGE READY TRANSPORT PROGRAM?

50 APPENDIX

55 GLOSSARY

GRID 101: GENERATION TO DISTRIBUTION

The electric grid serves as the bridge between power plants and electricity consumers. Most traditional power plants generate electricity by burning fuel such as natural gas to heat steam that then powers large generators. These centralized thermal (heat-based) power plants typically have large space requirements and are located for convenient access to their fuel source (e.g., near a natural gas pipeline or rail terminal). Electrical power can also be produced in smaller or less-centralized plants that use other mechanical energy to turn generators; some power plants of this type use hydro or wind energy. Solar plants work differently; they use photovoltaic cells to absorb sunlight and induce electron flow, thereby generating power. SCE's electric grid uses all of these types of power generation. Generally, a common trait among plants is that they are located further from population centers, where land use is less constrained and power plants have good access to their primary energy source (that is, natural gas, wind, sunshine and rivers).

To reach customers, power plants feed electricity into their local grid's network of transmission and distribution lines. As shown in Figure 22, step-up transformers prepare electricity for transmission in large volumes over long distances. These are analogous to water pumps that push water through pipes over hills and across long distances while regulating the pressure (voltage) at critical transition points.

Today, customers have more options to produce energy with on-site generators or distributed energy resources. These include rooftop solar photovoltaic panels, fuel cells, small wind turbines

FIGURE 22:
The electric grid carries electrical energy from generators to the end user.

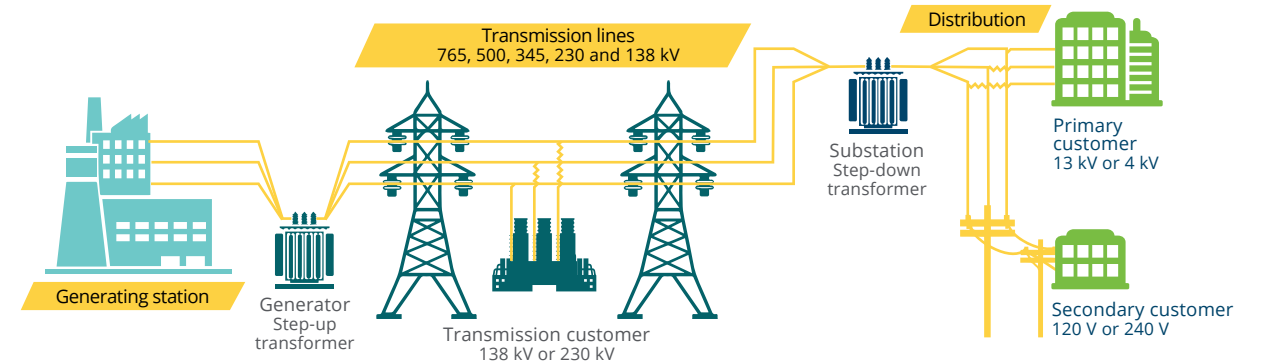

and battery energy storage systems. These distributed energy sources supplement the large centralized power plants by providing some or all of a customer's energy needs. Any customer-owned generation that connects to the grid is coordinated by interconnection requirements that utilities follow to ensure these new smaller generators work safely and reliably with the existing grid.

Generating, transmitting and consuming power involves multiple entities, which means that ownership structures vary across the electricity supply chain. Power plants may be publicly or privately owned. Independent system operators and utilities manage the electric grid. Utilities also provide maintenance to the grid and collect revenue from customers for the energy they use. Customers' prices vary by the time of day and rate at which the electricity is consumed. More details on the key components that go into the price of electricity for fleets are provided on page 17 in the **Transitioning to Electricity** section.

Utilities are responsible for expanding the grid's capacity to deliver power as more consumers connect to the system. Utilities also have a key responsibility in sustaining the grid's high reliability, which ensures that the power is there whenever it's needed. This includes ongoing grid maintenance and new infrastructure development to adapt to changes in how people use electricity. One of the recent changes in electricity use is the increasing appeal to power fleets of vehicles. To manage these responsibilities, utilities maintain regular inspection and operational review schedules for power lines, transformers and substations. As more EVs are put on the road, some utilities are developing long-term maintenance protocols for newly laid EV charging infrastructure. On the other side of this equation, consumers who own or operate vehicle chargers—referred to as EVSE—are responsible for conducting regular maintenance to ensure that their equipment safely and successfully receives power and transmits it to vehicles.

CHARGE READY TRANSPORT

2 EXECUTIVE SUMMARY

4 INTRODUCTION

6 TRANSITIONING TO ELECTRICITY FOR YOUR FLEET

33 SCE'S CHARGE READY TRANSPORT PROGRAM FOR MEDIUM- AND HEAVY-DUTY VEHICLES

38 SCE'S CHARGE READY TRANSPORT ELECTRIFICATION PROCESS

44 ONGOING MAINTENANCE AND SUPPORT FOR YOUR EV CHARGING INFRASTRUCTURE

47 CONTINUING THE PROCESS

49 INTERESTED IN THE CHARGE READY TRANSPORT PROGRAM?

50 APPENDIX

55 GLOSSARY

POWER MARKET 101: HOW POWER REACHES YOUR FLEET

A range of stakeholders coordinate closely to buy and sell electrical power on the grid. The initial vendor is the fuel provider who sells fuel to the power plant at a market-determined price; the power plant owner-operator may also be the fuel provider. Power plants sell the power they produce to utilities and other load-serving entities (LSEs) at prices determined under a variety of structures ranging from long-term power purchase agreements (PPAs) to last-minute bids for immediate use. These transactions are brokered by an independent system operator (ISO), which ensures that power flow across the grid is balanced, meaning that supply meets demand at all times. This is done by constantly and rapidly matching utility purchase requests with power plant sales bids.

Utilities and other LSEs, including community choice aggregators (CCAs), typically use PPAs to support their baseload power, or the minimum amount of power that they expect to provide at any given time. To meet next-daily needs, they buy power as it is bid on the day-ahead market, where market participants purchase and sell electric energy at financially binding prices for the following

day. Finally, to meet minute-to-minute needs, utilities and other LSEs buy power as it is bid on the spot market under immediate market conditions. This is typically the power with the most volatile pricing, with high costs during peak loads and low costs during low demand times of the day.

While utilities pay a range of prices to maintain balance in their service territories, they bill their customers at a predetermined rate that accounts for these fluctuations over the course of a billing cycle. Utilities' approaches to establishing these rates vary by their structure (Figure 27). SCE is an investor-owned utility (IOU), an entity that must receive approval for all rate changes from the California Public Utilities Commission (CPUC). Publicly owned utilities (POUs), also known as municipal utilities, apply rates set by their governing board or city council. The electricity rate structures used by many utilities include a time-of-use price of power for an EV fleet that can vary throughout the day, offering lower prices at less busy times (like late at night) and higher prices when energy use is highest across the grid. Further discussion on electricity rates as they affect your bill is provided in the section **Transitioning to Electricity for your Fleet**.



TERMS YOU NEED TO KNOW

PPA: Power purchase agreement, a contract for one entity to delivery power to another over a defined period of time

CCA: Community choice aggregator, an alternative to the investor-owned utility energy supply system in which local government entities aggregate buying power within a defined jurisdiction

ISO: Independent system operator, an entity that monitors, coordinates and directs operations on the electric grid

Day-ahead market: Market on which power is traded for next-day delivery

Spot market: Market on which power is traded for immediate delivery

CHARGE READY TRANSPORT



Glossary

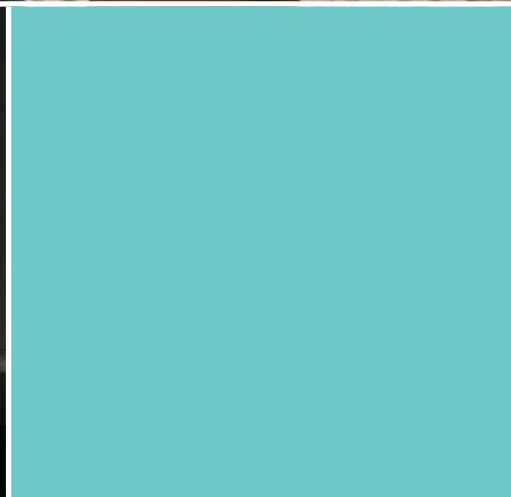
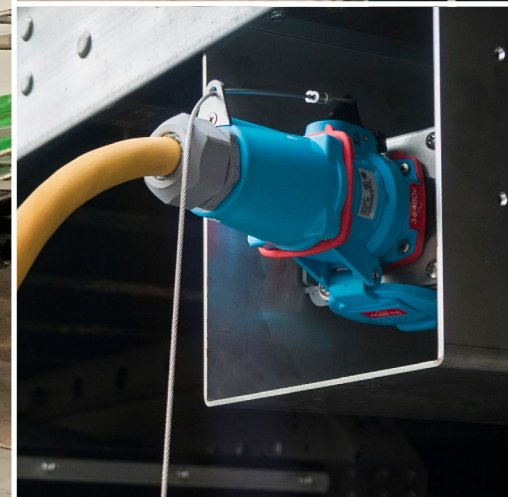

GLOSSARY

Amperage: A measure of the flow of electrical charge

Average power: The average amount of power that your fleet requires at any given time while charging

BEV: Battery electric vehicle is a specific term used to distinguish it from a plug-in hybrid electric vehicle (PHEV).

CCA: Community choice aggregator, an alternative to the investor-owned utility energy supply system in which local government entities aggregate buying power within a defined jurisdiction

Charge rate: The rate at which a battery can charge, measured in kilowatts (kW)

Charging window: The period of time in your fleet's duty cycle when vehicles can charge, measured in hours

Day-ahead market: Market on which power is traded for next-day delivery

DCFC: Direct current fast charge, usually stated as DC fast charge

Distribution: The process of delivering power from transmission lines to the customer

Duty cycle: The proportion of time during which a vehicle is operated.

EV: An electric vehicle

EV demand: The amount of power supplied to EVs during charging

EVSE: Electric vehicle supply equipment

Generation: The process of producing electricity from a fuel or other energy source

IOU: Investor-owned utility

ISO: Independent system operator, an entity that monitors, coordinates and directs operations on the electric grid

kWh: Kilowatt-hour, the unit of measure for electrical energy

Load profile: The amount(s) of power that your fleet requires on an hourly basis over the course of a day

LCFS: Low Carbon Fuel Standard

Meter: A device that records the amount of power flowing through a circuit

PPA: Power purchase agreement, a contract for one entity to delivery power to another over a defined period of time

POU: Publicly owned utility

Peak shaving: A strategy to reduce power consumption during periods of high demand

Rate structure: A set of parameters used to define the prices that a customer may be charged for power over time

ROM: Rough order of magnitude, an estimation of a project's level of effort and cost to complete

Spot market: Market on which power is traded for immediate delivery

Substation: A set of electric equipment that reduces high-voltage power to a voltage suitable for customer use

Transformer: An electric device that changes electricity from one level of voltage to another

Transmission: The process of moving power in large quantities across long distances

Voltage: Electrical pressure created by a difference in electrical potential

ZEV: Zero-emission vehicle